

MS5534A

BAROMETER MODULE

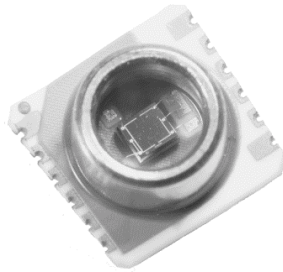

- ◆ Integrated pressure sensor
- ◆ Pressure range 300-1100 mbar
- ◆ 15 Bit ADC
- ◆ 6 coefficients for a software compensation stored on-chip
- ◆ 3-wire serial interface
- ◆ 1 system clock line (32.768 kHz)
- ◆ Low voltage / low power

DESCRIPTION

The MS5534A is a SMD-hybrid device including a piezoresistive pressure sensor and an ADC-Interface IC. It provides a 16 Bit data word from a pressure- and temperature-dependent voltage. Additionally the module contains 6 readable coefficients for a highly accurate software calibration of the sensor. MS5534A is a low-power, low-voltage device with automatic power down (ON/OFF) switching. A 3-wire interface is used for all communications with a microcontroller. Sensor packaging options are plastic or metal cap.

FEATURES

- 15-Bit ADC resolution
- Supply voltage 2.2 V to 3.6 V
- Low Supply current
- -40°C to +60°C
- Small size
- No external components required

APPLICATIONS

- Mobile altimeter/barometer systems
- Weather control systems
- Adventure or multi-mode watches
- GPS Receivers

BLOCK DIAGRAM

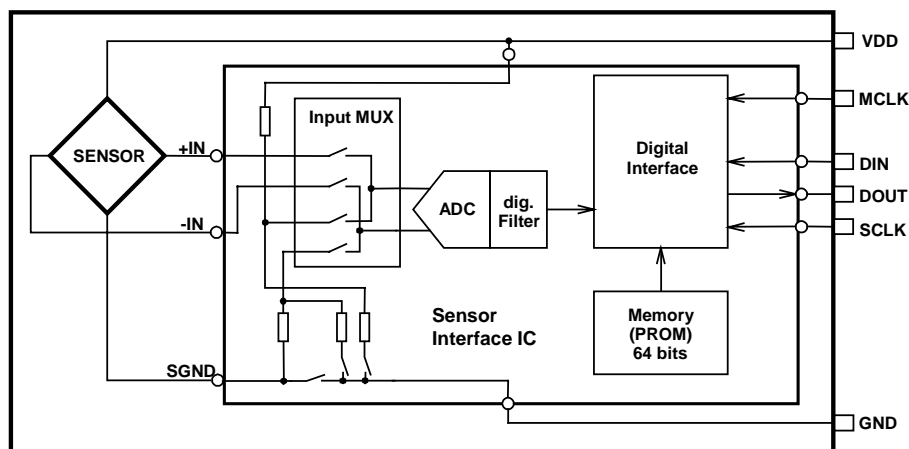

Fig.: 1 Block Diagram 5534

PIN CONFIGURATION

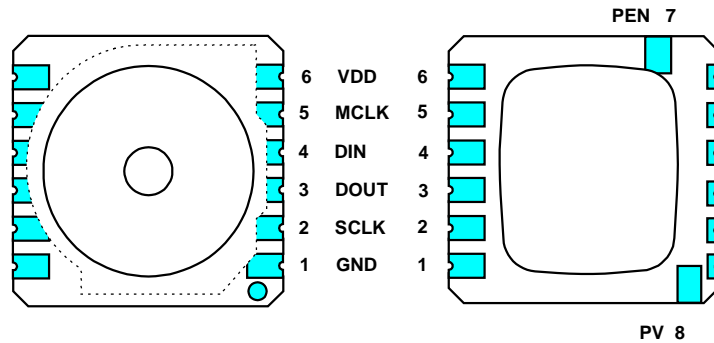

Fig. 2: Pin configuration of MS5534

PIN DESCRIPTION

Pin Name	Pin	Type	Function
VDD	6	P	Positive Supply Voltage
MCLK	5	I	Master Clock (32.768kHz)
DIN	4	I	Data Input
DOUT	3	O	Data Output
SCLK	2	I	Serial Data Clock
GND	1	G	Ground
PV	8	N	Negative Programming Voltage
PEN	7	I	Programming Enable

Note: Pins 7 (PEN) and 8 (PV) are only used by the manufacturer for calibration purposes and should not be connected.

ABSOLUTE MAXIMUM RATINGS

Parameter	Symbol	Conditions	Min	Max	Unit
Supply Voltage	V_{DD}		-0.3	4	V
Overpressure	P			4	bar abs
Storage Temperature	T_{Stg}		-20	+70	°C

Notes:

1. Storage and operation in an environment of dry and non-corrosive gases.

RECOMMENDED OPERATING CONDITIONS

(T=25°C, VDD=3.0V unless noted otherwise)

Parameter	Symbol	Conditions	Min.	Typ.	Max	Unit
Supply Voltage	V _{DD}		2.2	3.0	3.6	V
Supply Current, average (1) during conversion (2) standby (no conversion)	I _{avg} I _{SC} I _{SS}	V _{DD} = 3.0 V		5 1	3.5	μA mA μA
Current consumption into MCLK (3)		MCLK=32768Hz			0.5	μA
Operating pressure range	p		300		1100	mbar abs.
Operating temperature range	T _a		-10	+25	+60	°C
Conversion time	T _{conv}	MCLK=32768Hz			35	ms
External clock signal (4)	MCLK		30000	32768	35000	Hz
Duty cycle of MCLK			40/60	50/50	60/40	%
Serial Data Clock	SCLK				500	kHz

Notes:

1. Under the assumption of one conversion every second. Conversion means either a pressure or a temperature measurement started by a command to the serial interface of MS5534.
2. During conversion the sensor will be switched on and off in order to reduce power consumption; the total on time within a conversion is about 2ms.
3. This value can be reduced by switching off MCLK while MS5534 is in standby mode.
4. It is strongly recommended that a crystal oscillator be used because the device is sensitive to clock jitter. A square-wave form of the clock signal is a must.
5. Reliable operation requires protection of the pressure sensor from direct contact with light.
6. Power supply pins (VDD, GND) must be decoupled with a tantalum (47μF) capacitor placed close to the module.

ELECTRICAL CHARACTERISTICS

◆ Digital inputs

(T=-40°C .. 60°C)

Parameter	Symbol	Conditions	Min	Typ	Max	Unit
Input High Voltage	V_{IH}	$V_{DD} = 2.2...3.6V$	80% V_{DD}		100% V_{DD}	V
Input Low Voltage	V_{IL}	$V_{DD} = 2.2...3.6 V$	0% V_{DD}		20% V_{DD}	V
Signal Rise Time	t_R			200		ns
Signal Fall Time	t_f			200		ns

◆ Digital outputs

(T=-40°C .. 60°C, $V_{DD} = 2.2V..3.6V$)

Parameter	Symbol	Conditions	Min	Typ	Max	Unit
Output High Voltage	V_{OH}	$I_{Source} = 0.6 \text{ mA}$	75% V_{DD}		100% V_{DD}	V
Output Low Voltage	V_{OL}	$I_{Sink} = 0.6 \text{ mA}$	0% V_{DD}		20% V_{DD}	V
Signal Rise Time	t_r			200		ns
Signal Fall Time	t_f			200		ns

◆ AD-converter

(T=25°C, $V_{DD} = 3.0V$)

Parameter	Symbol	Conditions	Min	Typ	Max	Unit
Resolution (1)				15		Bit
Conversion Time		MCLK=32768Hz			35	ms
Accuracy (2)				2	7	LSB

Notes:

7. The ADC output range is from 5,000 counts to 37,000 counts, thus providing a 16-Bit output word.
8. Accuracy limited by the non-linearity of the ADC.

PRESSURE OUTPUT CHARACTERISTICS

With the calibration data provided by the MS5534 system (stored in the interface IC) the following characteristics can be achieved:

Parameter	Conditions	Min	Typ	Max	Unit	Note
Resolution			0.1		mbar	1
Absolute Pressure Accuracy	$p = 750 \dots 1100\text{mbar}$ $T_a = 25^\circ\text{C}$	-1.5		+1.5	mbar	2
Relative Pressure Accuracy	$p = 750 \dots 1100\text{mbar}$ $T_a = 25^\circ\text{C}$	-0.5		+0.5	mbar	3
Maximum Error over Temperature	$T_a = -10\dots+60^\circ\text{C}$ $p = \text{const.}$	-1		+1	mbar	4
		-1		+6	mbar	5
Long-term Stability	12 month		-1		mbar	6
Maximum Error over Supply Voltage	VDD = 2.2...3.6V	-1.5	0	+1.5	mbar/V	

Notes:

1. A stable pressure reading of the given resolution requires to take the average of 2 to 4 subsequent pressure values due to noise of the ADC. A better resolution can be obtained with more averaging.
2. Maximum error of pressure reading over the pressure range.
3. Maximum error of pressure reading over the pressure range after offset adjustment at one pressure point.
4. With the second-order temperature compensation as described in Section "Calculation of pressure using compensation coefficients C1 to C5".
5. With the first-order temperature compensation as described in Section "Calculation of pressure using compensation coefficients C1 to C5".
6. The long-term stability is measured with non-soldered devices

TEMPERATURE OUTPUT CHARACTERISTICS

This temperature information is not required for most applications, but it is necessary to allow for temperature compensation of the pressure output. The reference temperature is 20°C.

Parameter	Conditions	Min	Typ	Max	Unit
Resolution		0.005		0.015	°C
Accuracy	at reference temperature	-0.8		0.8	°C
Maximum Error over Supply Voltage	VDD = 2.2...3.6V	-0.08		+ 0.08	°C/V

Notes:

1. Refer to the paragraph second-order temperature compensation in the section 'FUNCTION'

TYPICAL PERFORMANCE CURVES

ADC-value vs Pressure (typical)

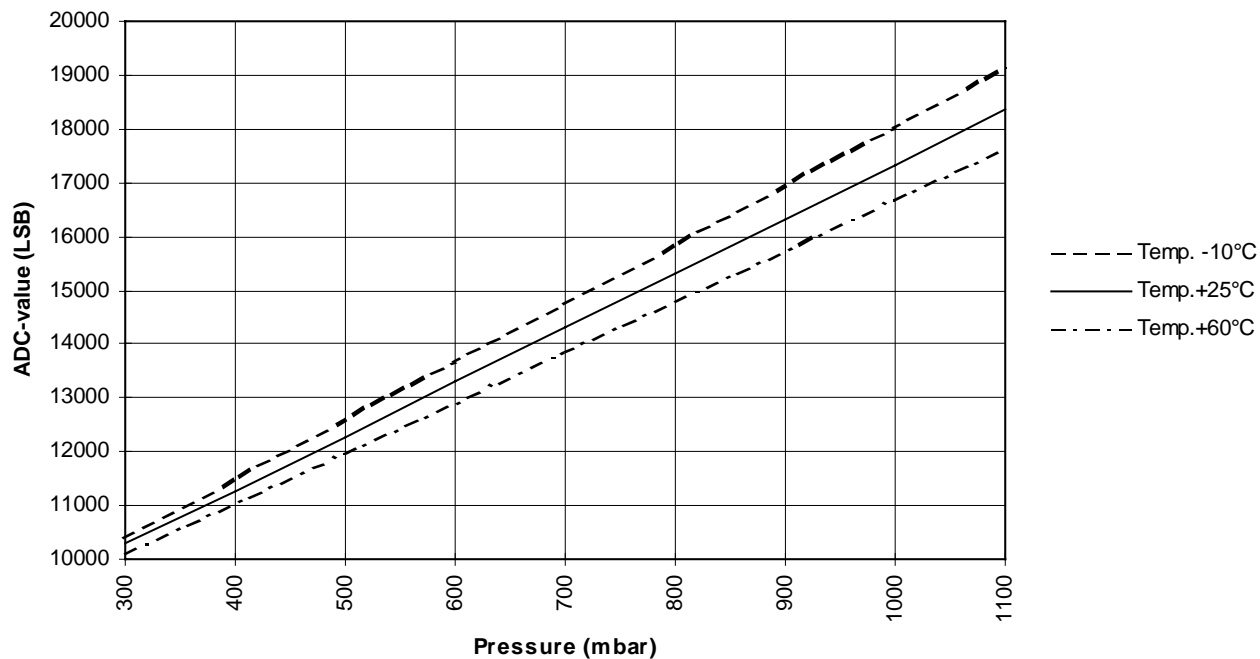

ADC-value D2 vs Temperature (typical)

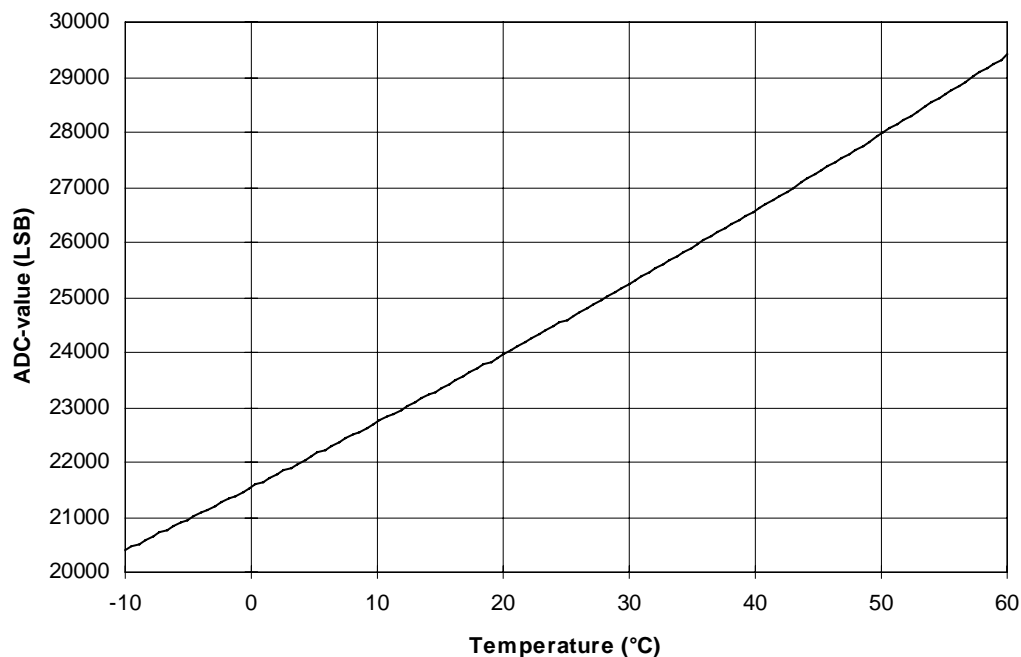

Absolute pressure accuracy after calibration (typical)

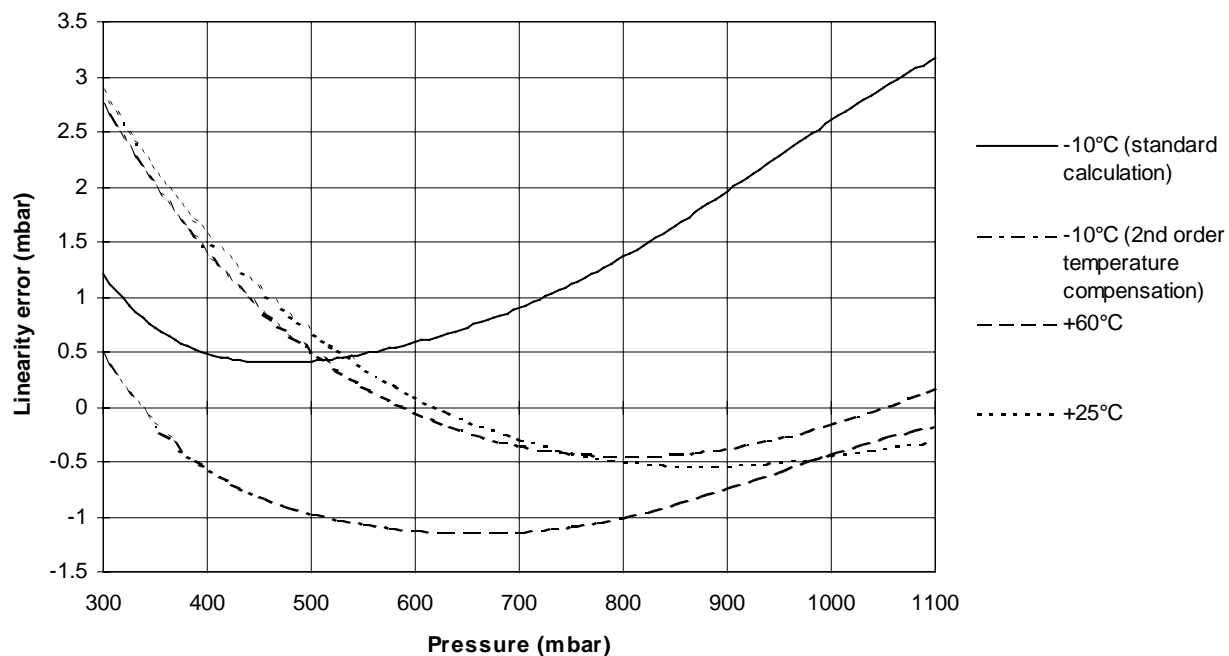

Accuracy vs temperature (typical)

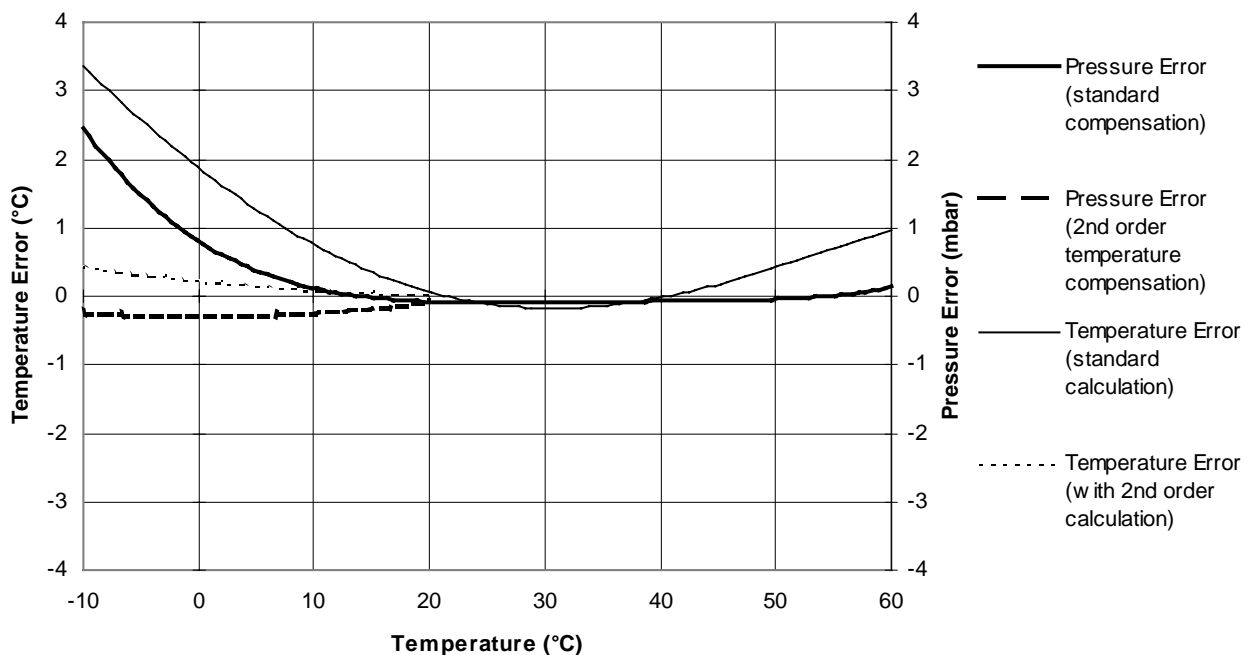

Pressure error vs supply voltage (typical)

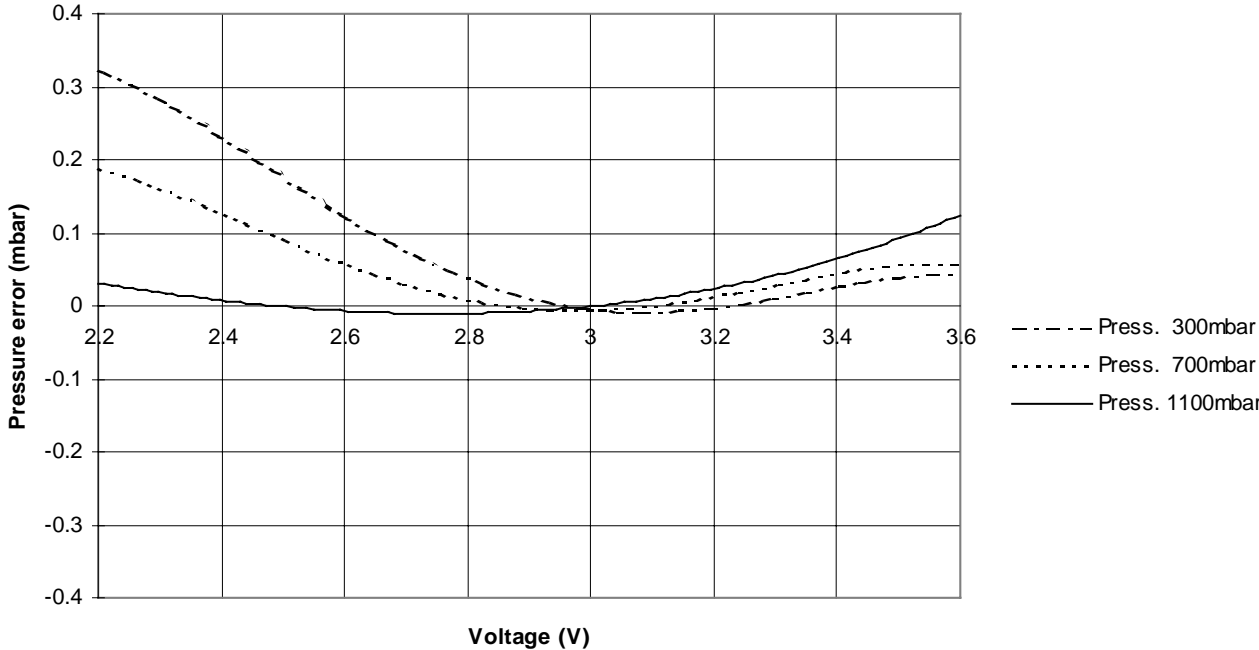

Temperature error (25°C) vs supply voltage (typical)

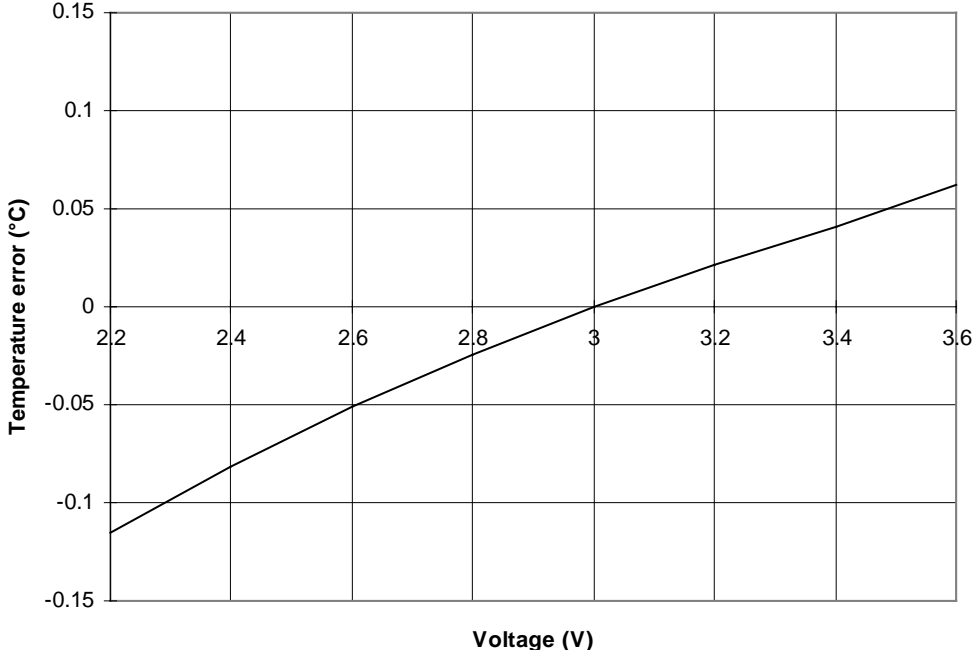

FUNCTION

◆ General

The MS5534 consists of a piezoresistive sensor and a sensor interface IC. The main function of the MS5534 is to convert the uncompensated analog output voltage from the piezoresistive pressure sensor to a 16-Bit digital value, as well as providing a 16-Bit digital value for the temperature of the sensor.

- measured pressure (16-Bit) "D1"
- measured temperature (16-Bit) "D2"

As the output voltage of a pressure sensor is strongly dependent on temperature and process tolerances, it is necessary to compensate for these effects. This compensation procedure must be performed by software using an external microcontroller.

◆ Factory calibration

Every module is individually factory calibrated at two temperatures and two pressures. As a result, 6 coefficients necessary to compensate for process variations and temperature variations are calculated and stored in the 64-Bit PROM of each module. These 64-Bit (partitioned into four words of 16-Bit) must be read by the microcontroller software and used in the program converting D1 and D2 into compensated pressure and temperature values.

◆ Pressure and temperature measurement

The sequence of reading pressure and temperature as well as of performing the software compensation is depicted in flow chart, Fig. 3 and Fig. 5.

First the WORD1 to WORD4 have to be read through the serial interface. This can be done once after reset of the microcontroller that interfaces to the MS5534. Next the compensation coefficients C1 to C6 are extracted using Bit-wise logical- and shift-operations (refer to Fig. 4 for the Bit-pattern of word 1 to word 4).

For the pressure measurement the microcontroller has to read the 16 Bit values for pressure (D1) and temperature (D2) via the serial interface in a loop (for instance every second). Then, the compensated pressure is calculated out of D1, D2 and C1 to C6 according to the algorithm in Fig. 3 (possibly using quadratic temperature compensation according to Fig. 5). All calculations can be performed with signed 16-Bit variables. Results of multiplications may be up to 32-Bit long (+sign). In the flow according to Fig. 3 each multiplication is followed by a division. This division can be performed by Bit-wise shifting (divisors are to the power of 2). It is ensured that the results of these divisions are less than 65536 (16-Bit).

For the timing of signals to read out WORD1 to WORD4, D1, and D2 please refer to the paragraph "Serial Interface".

◆ Measurement principle

For both pressure and temperature measurement the same ADC is used (sigma delta converter):

- for the pressure measurement, the differential output voltage from the pressure sensor is converted
- for the temperature measurement, the sensor bridge resistor is sensed and converted

During both measurements the sensor will only be switched on for a very short time in order to reduce power consumption. As both, the bridge bias and the reference voltage for the ADC are derived from VDD, the digital output data is independent of the supply voltage. The A/D converter has been optimized to work in the linear range (numeric values in range [5,000:37,000]).

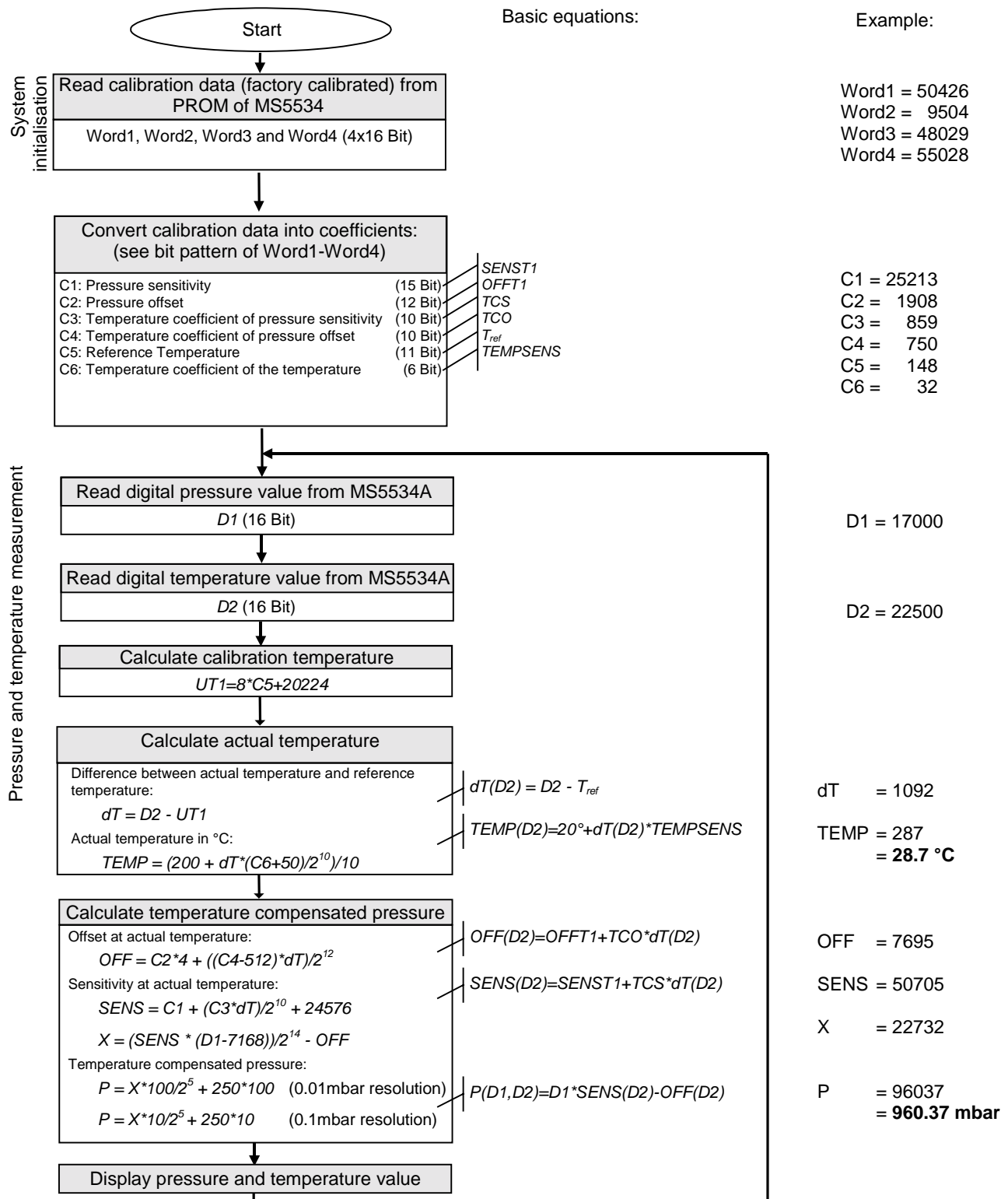

Fig. 3: Flow chart for pressure/temperature reading and software compensation.

Notes:

1. Readings of D2 can be done less frequently, but the display will be less stable in this case
2. For a stable display of 0.1mbar resolution, it is recommended to display the average of 8 subsequent pressure values.

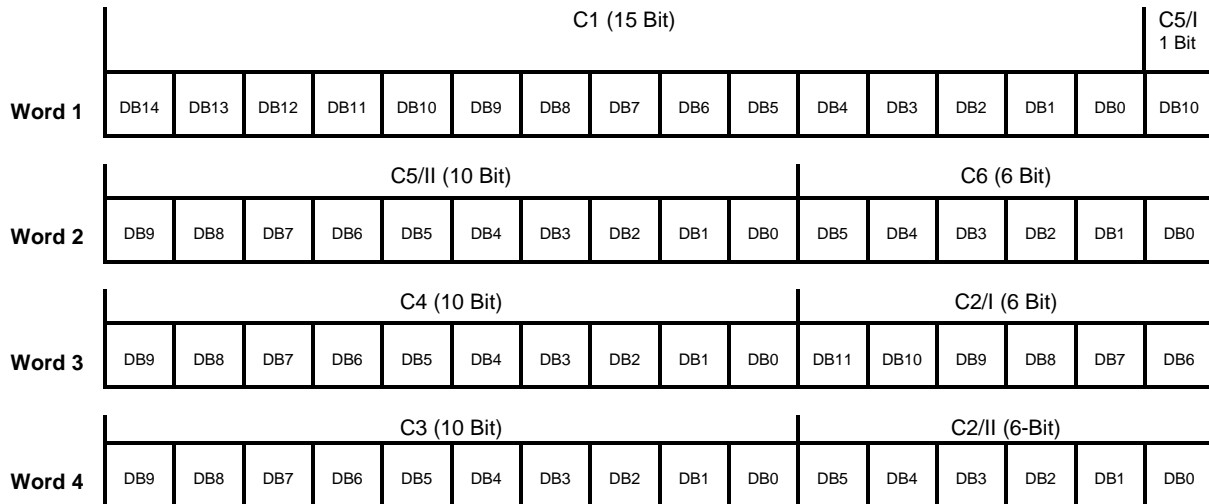

Fig. 4: Arrangement (Bit-pattern) of calibration data in Word1 to Word4.

◆ **Second-order temperature compensation**

In order to obtain full accuracy over the whole temperature range, it is recommended to compensate for the non-linearity of the output of the temperature sensor. This can be achieved by the second-order temperature calculation for $D2 < UT1$, i.e. by replacing the block "Calculate actual temperature" in flow chart Fig. 3 by the following sequence:

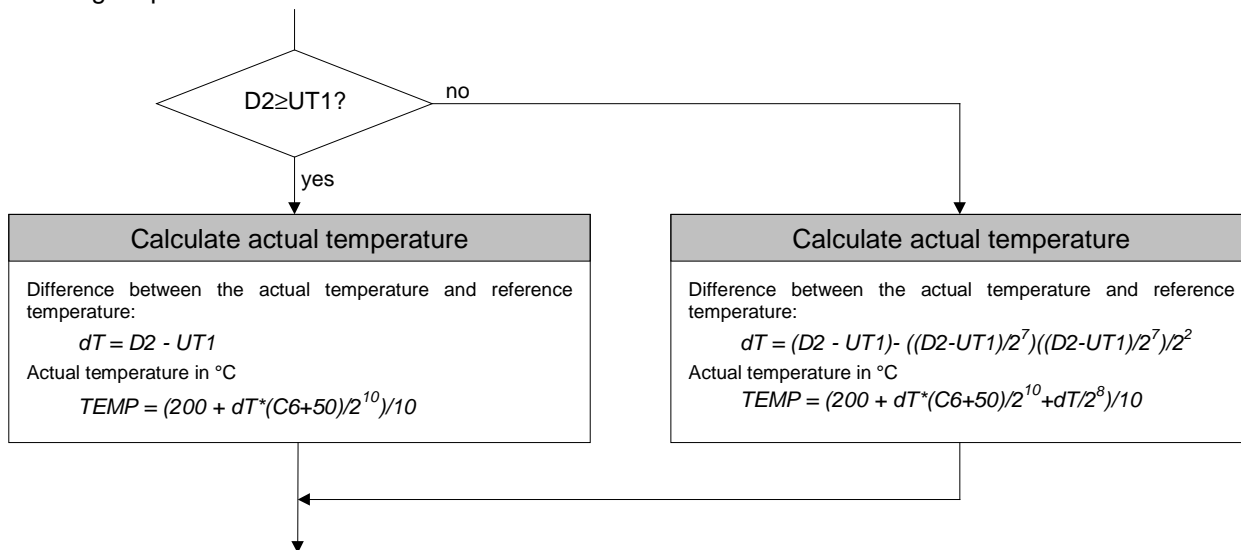

Fig. 5: Flow chart for calculating the temperature to the optimum accuracy. The value for dT thus obtained is then used for the calculation of the temperature compensated pressure as shown in Fig.3.

◆ Serial interface

The MS5534 communicates with microprocessors and other digital systems via a 3-wire synchronous serial interface as shown in Fig. 1. The SCLK (Serial Clock) signal initiates the communication and synchronizes the data transfer with each Bit being sampled by the MS5534 on the rising edge of SCLK and each Bit being sent by the MS5534 on the rising edge of SCLK. The data should thus be sampled by the microcontroller on the falling edge of SCLK and sent to the MS5534 with the falling edge of SCLK. The SCLK-signal is generated by the microprocessor's system. The digital data provided by the MS5534 on the DOUT pin is either the conversion result or the software calibration data. In addition the signal DOUT (Data Out) is also used to indicate the conversion status (conversion-ready signal, see below). The selection of the output data is done by sending the corresponding instruction on the pin DIN (Data Input).

Following is a list of possible output data instructions:

- Conversion start for pressure measurement and ADC-data-out "D1" (Figure 6a)
- Conversion start for temperature measurement and ADC-data-out "D2" (Figure 6b)
- Calibration data read-out sequence for word 1 (Figure 6c)
- Calibration data read-out sequence for word 2 (Figure 6d)
- Calibration data read-out sequence for word 3 (Figure 6c)
- Calibration data read-out sequence for word 4 (Figure 6d)
- RESET sequence (Figure 6e)

Every communication starts with an instruction sequence at pin DIN. Fig. 6 shows the timing diagrams for the MS5534. The device does not need a 'Chip select' signal. Instead there is a Start Sequence (3-Bit high) before each Setup Sequence and Stop Sequence (3-Bit low) after each Setup Sequence. The Setup Sequence consists in 4-Bit that select a reading of pressure, temperature or calibration data. In case of pressure- (D1) or temperature- (D2) reading the module acknowledges the start of a conversion by a low to high transition at pin DOUT during the last bit of the Stop Sequence.

Two additional clocks at SCLK are required after the acknowledge signal. Then SCLK is to be held low by the microcontroller until a high to low transition on DOUT indicates the end of the conversion.

This signal can be used to create an interrupt in the microcontroller. The microcontroller may now read out the 16-Bit word by giving another 17 clocks on the SCLK pin. It is possible to interrupt the data read-out sequence with a hold of the SCLK signal.

It is important to always read out the last conversion result before starting a new conversion.

The RESET-sequence is special as its unique pattern is recognized by the module in any state. By consequence it can be used to restart if synchronization between the microcontroller and the MS5534 has been lost. This sequence is 21-Bit long. The DOUT signal might change during that sequence (see Fig. 6e).

It is thus recommended to send the RESET-Sequence before each Conversion Sequence to avoid hanging up the protocol permanently in case of electrical interference.

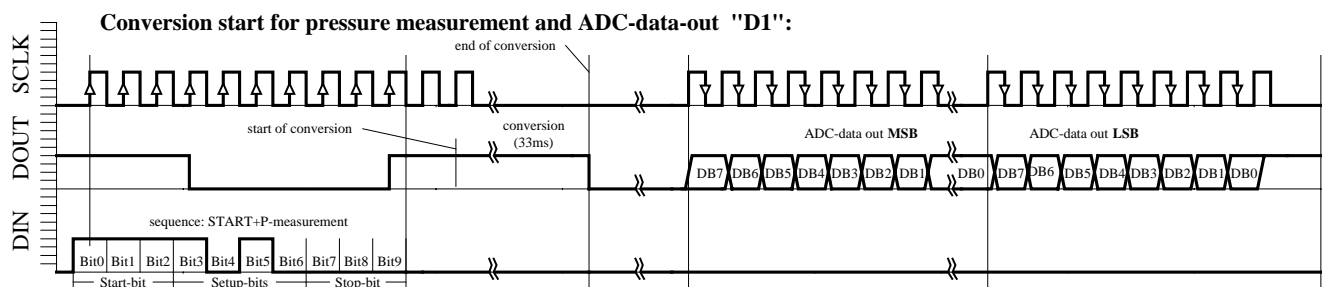

Fig. 6a: D1 acquisition sequence

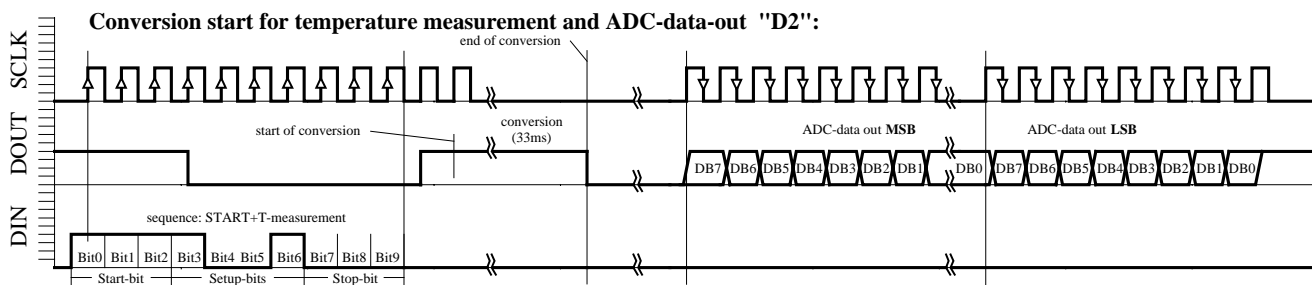

Fig. 6b: D2 acquisition sequence

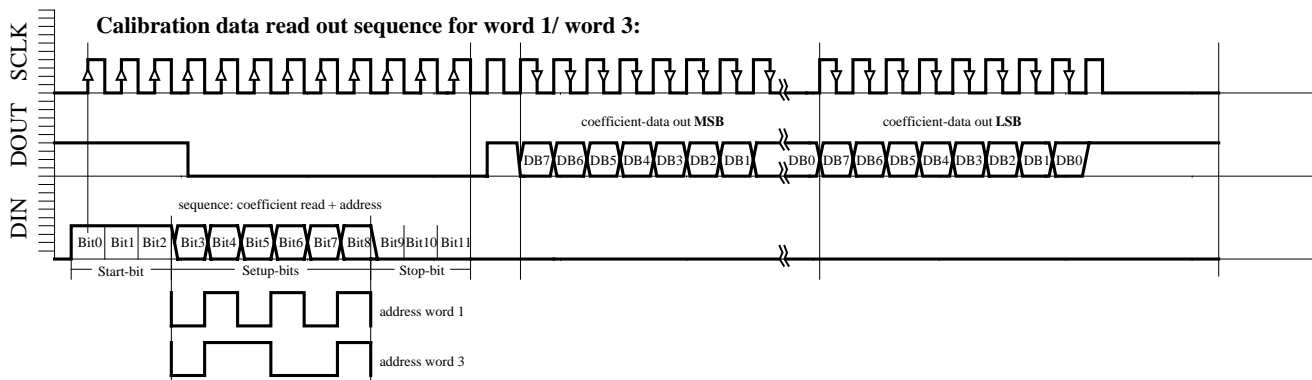

Fig. 6c: W1, W3 reading sequence

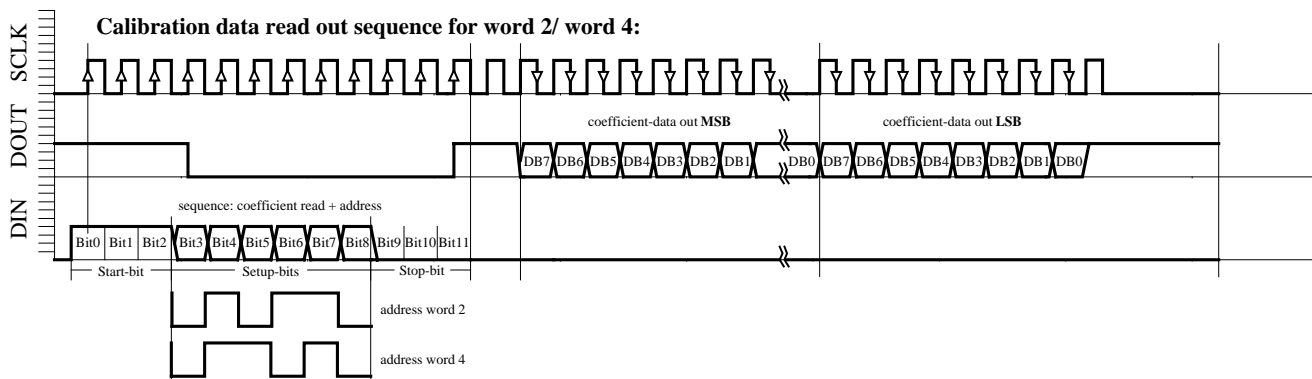

Fig. 6d: W2, W4 reading sequence

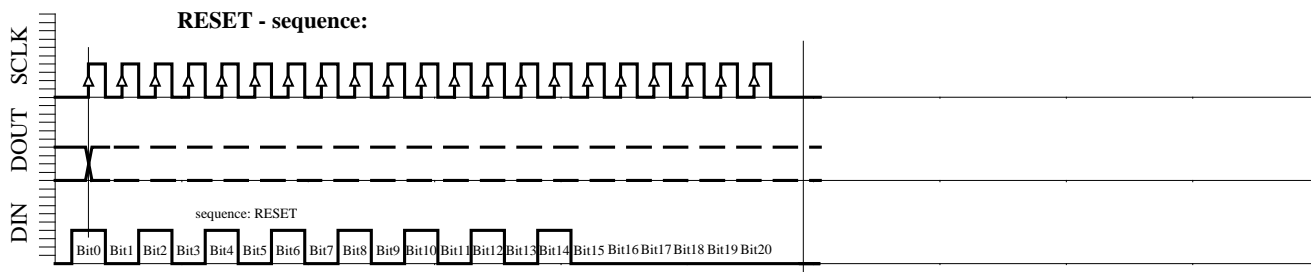

Fig. 6e: Reset sequence (21-Bit)

APPLICATION INFORMATION

◆ GENERAL

The idea for this combination of a sensor with a direct adapted integrated circuit is to save other external components and to achieve very low power consumption. The main application field for this system includes portable devices with battery supply, but its high accuracy and resolution make it also suited for industrial and automotive applications. The possibility to compensate the sensor with a software allows the user to adapt it to his particular application. Communication between the MS5534A and the widely available microcontrollers is realized over an easy-to-use 3-wire serial interface. Customers may select which microcontroller system to be used, and there are no specific standard interface cells required, which may be of interest for specially designed 4 Bit-microcontroller applications.

Storage of calibration data in the device will be done at module final test. Automatic test equipment is used to perform tests under pressure and temperature and to calculate individual coefficients for every sensor, which allows a highly accurate compensation.

Further, because the calibration data is stored in the MS5534A, the user can save additional external memory in his microcontroller system (i.e. EEPROM).

The MS5534A is mounted on a ceramic substrate. SnPb connection pads ensure the soldering of the substrate and automatic assembly. Standard surface mount techniques can be used (IR reflow soldering technique at temperatures not exceeding 225° C for 30 sec is recommended). A dot on the ceramic substrate marks pad 1. The silicon pressure transducer and the bonding wires are protected by a plastic cap on the standard version. MS5534AP is factory protected against humidity by a silicone gel. Version MS5534AM carries a metal protection cap filled with silicone gel for enhanced protection against humidity.

The package outline of the module allows the use of a flexible PCB to connect it. This can be important for applications in watches and other special devices, and will also reduce mechanical stress on the device.

For applications subjected to mechanical shock, it is recommended to enhance the mechanical reliability of the solder junctions by covering the rim or the corners of MS5534A's ceramic substrate with glue or glob top-like material.

Particular care must be taken when connecting the device to power supply: A 47 μ F tantalum capacitor **must** be placed as close as possible of the MS5534's VDD pin. This capacitor will stabilize the power supply during data conversion and thus, provide the highest possible accuracy.

◆ ALTIMETER SYSTEM USING MS5534A

MS5534A is a circuit that can be used in connection with a microcontroller in mobile altimeter applications. It is designed for low-voltage systems with a supply voltage of 3V, particularly in battery applications. The MS5534A is optimised for low current consumption as the AD-converter clock (MCLK) can use the 32.768kHz frequency of a standard watch crystal, which is supplied in most portable watch systems.

For applications in altimeter systems Intersema can deliver a simple formula to calculate the altitude, based on a linear interpolation, where the number of interpolation points influences the accuracy of the formula.

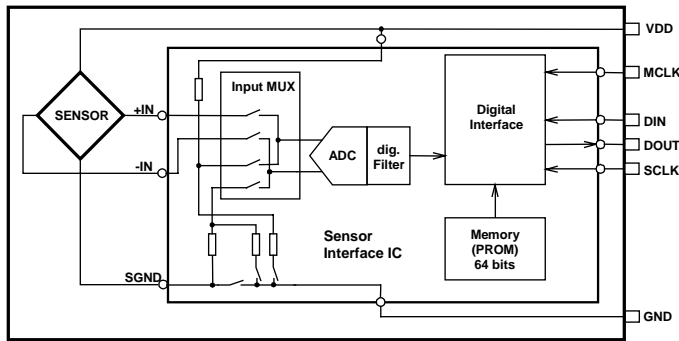

Figure 7: Block diagram of MS5534A

Advantages of MS5534:

- easy layout (one side contact for flexible PCB)
- better reliability
- reduced test time
- universal to use, less development time
- high compensation accuracy because of individual sensor test
- lower price as a solution with sensor, amplifier, AD-converter and external parts
- easy-to-use 3 wire serial interface

◆ APPLICATION EXAMPLES

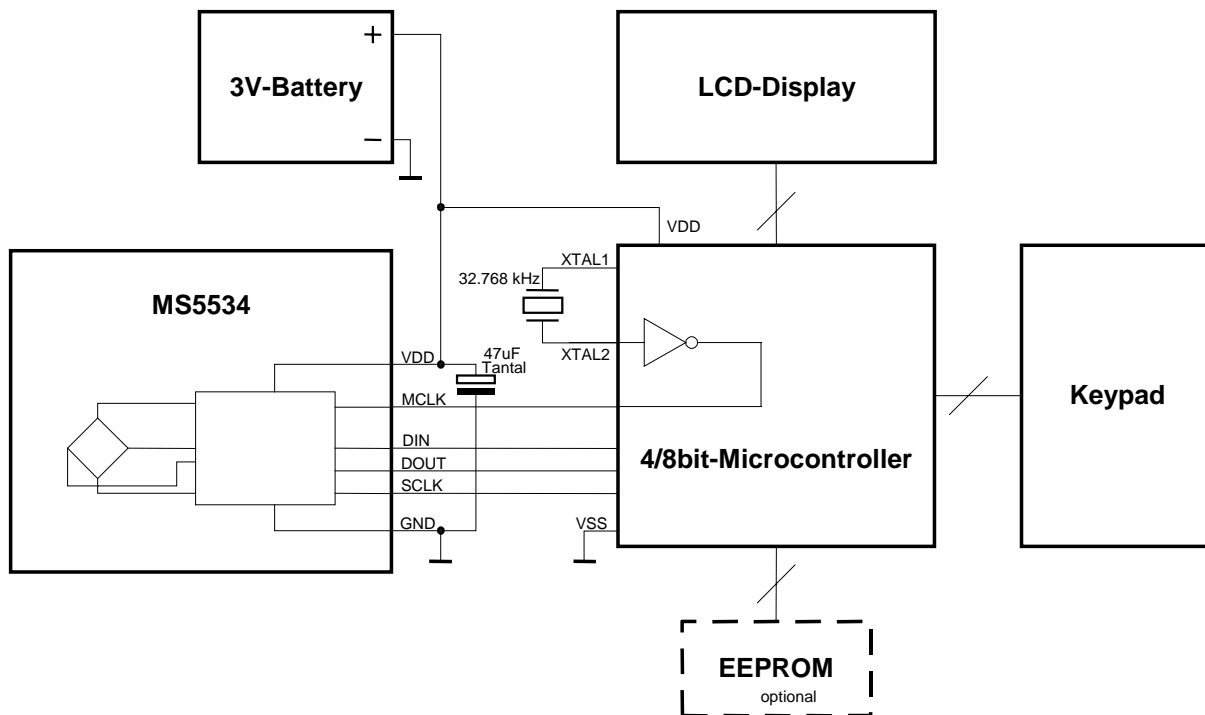

Figure 8: Demonstration of MS5534A in a mobile altimeter

DEVICE PACKAGE OUTLINES

◆ MS5534AP

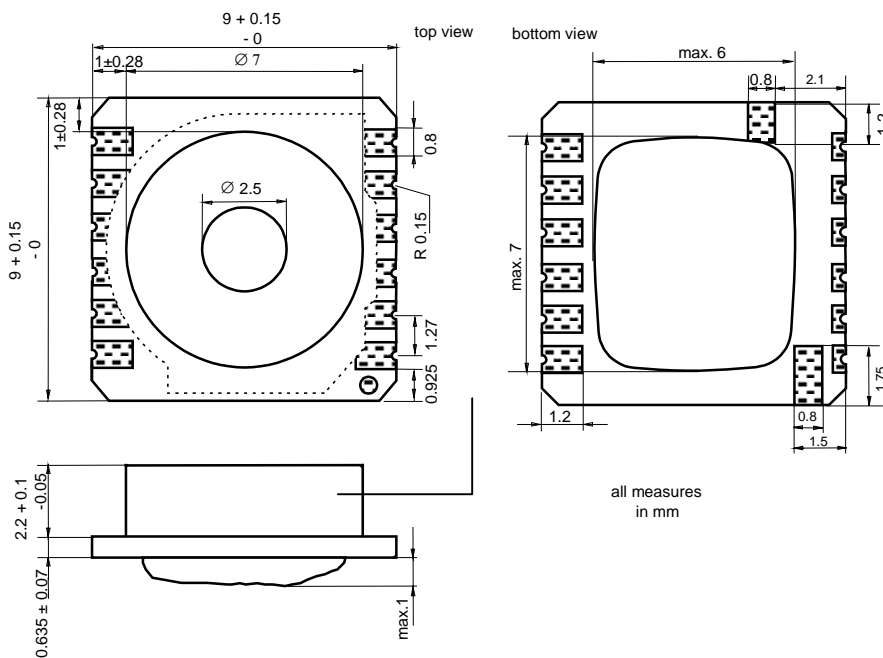

Fig. 9: Device package outlines of MS5534AP

◆ MS5534AM

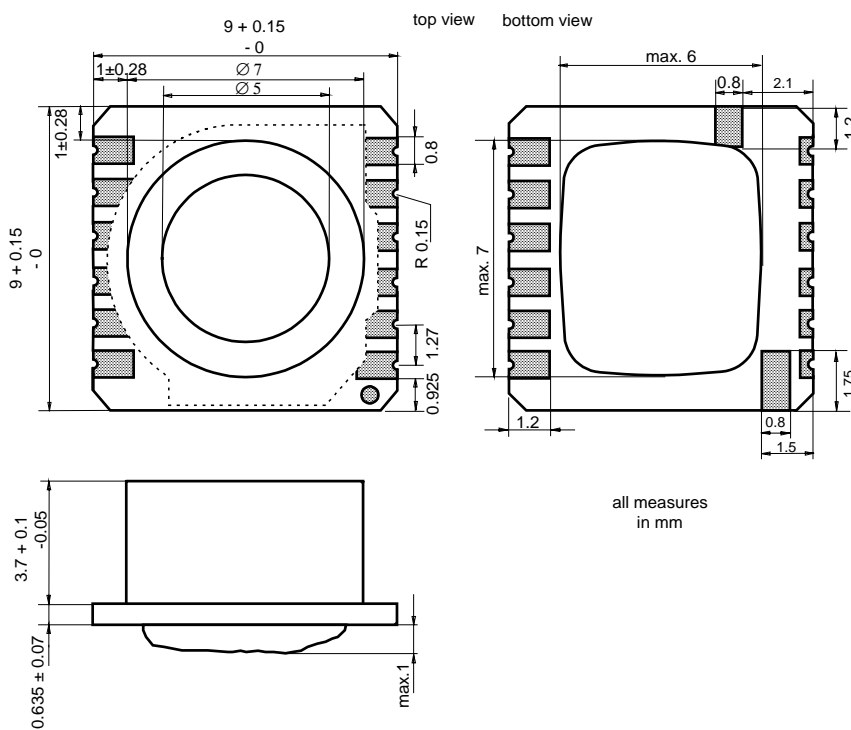
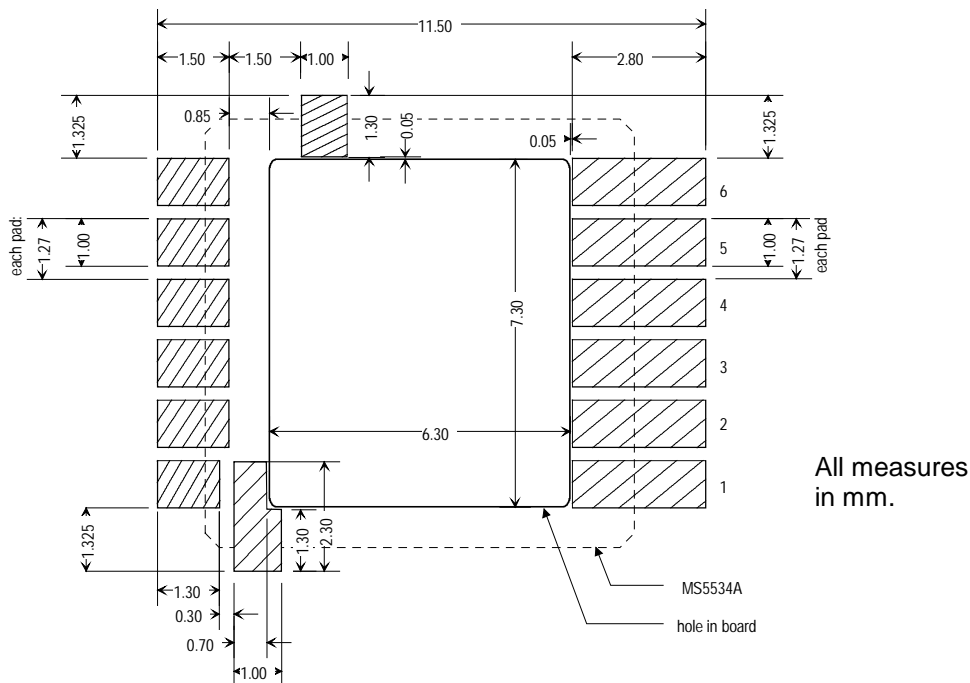

Fig. 10: Device package outlines of MS5534AM

RECOMMENDED PAD LAYOUT

◆ Pad layout for bottom side of MS5534A soldered onto printed circuit board



◆ Pad layout for top side of MS5534A soldered onto printed circuit board

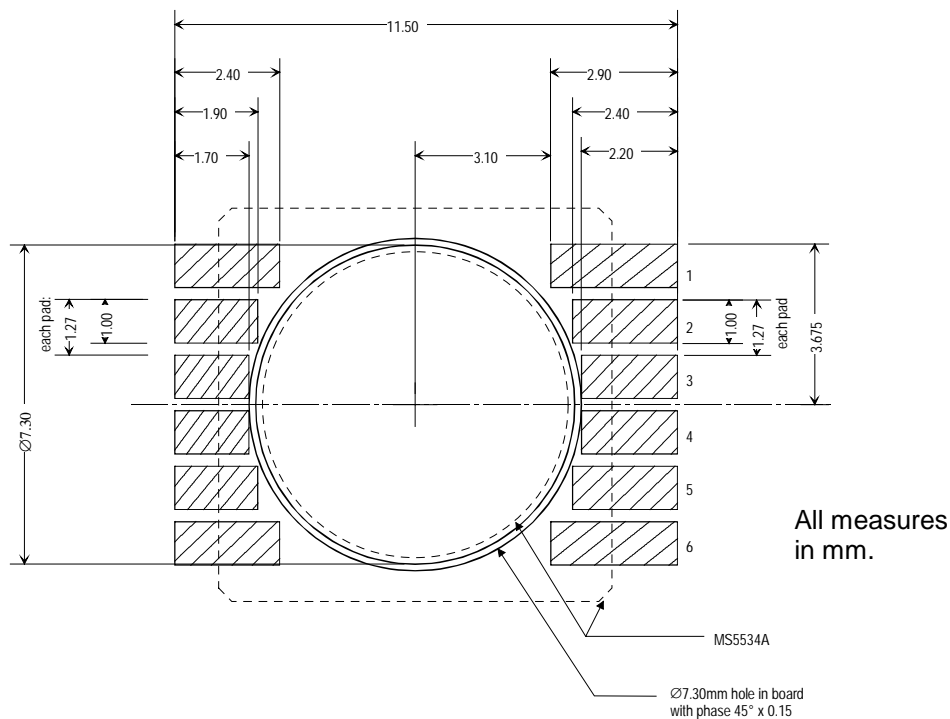

ASSEMBLY

◆ Soldering MS5534A

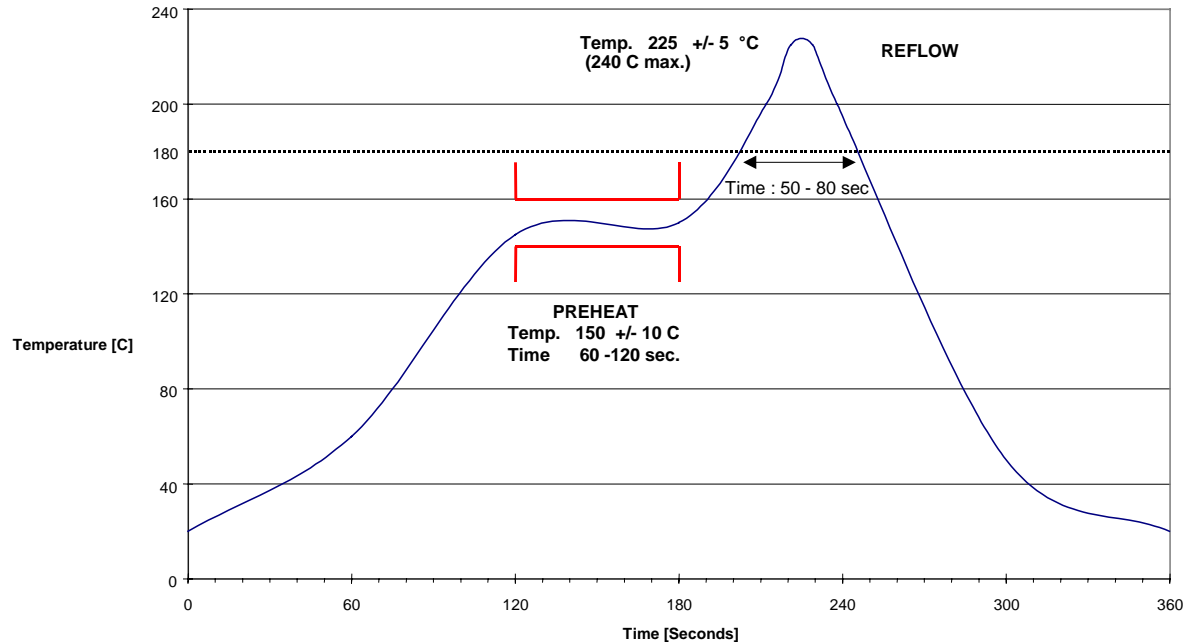

Figure 11: Recommended soldering profile

◆ Solder Paste

The MS5534A is a ceramic device that requires special assembly considerations compared to the assembly of SMD leaded components. The connecting pads are made of AgPd (Silver Palladium) pads. Like for other ceramic devices the sensor must be soldered with Sn62Pb36Ag2 Solder paste. This solder paste contains 2% of silver which avoids silver migration from the AgPd pad into the solder paste. The melting point of this paste is slightly lower (179°C) than the the standard Sn63Pb37 solder paste.

DO NOT USE SN63PB37 Solder Paste for soldering MS5534A !

◆ Soldering Quality

A good solder connection should look like shown on the photo to the below left forming a slight angle and filling the via almost to the top. **DO ALWAYS SOLDER BY REFLOW** using the recommended reflow profile. Soldering by hand will in most cases result in overheating of the device due to the good thermal conductivity of the ceramic. It is recommended to optimize the profile attaching a thermocouple to the sensor. Too low temperature will result in incomplete soldering resulting in a much less strong connection to the PCB as can be seen on the photo below right. For prototyping purposes cables can be soldered to the solder bumps on the backside of the sensor. The cable should be very thin to avoid lifting off the contact pad from the ceramic. Wire wrap cables will normally do a good job.



Good Solder Contact



Bad Solder Contact

◆ Mechanical Stress

It is recommended to avoid mechanical stress on the PCB on which the sensor is mounted. The thickness of the PCB should be not below 1.6mm. A thicker PCB is more stiff creating less stress on the soldering contacts. For applications where mechanical stress cannot be avoided (for example ultrasound welding of the case or thin PCB's in watches) please fix the sensor with drops of low stress epoxy (for example Hysol FP-4401) at the corners of the sensor as shown below.

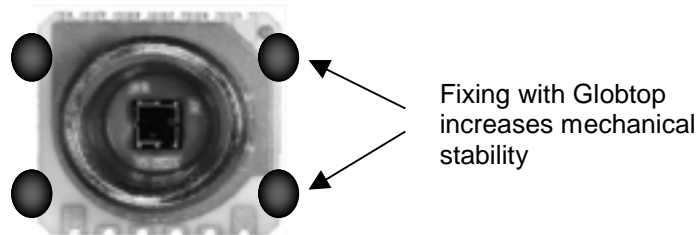

◆ Mounting

The MS5534A can be placed with automatic Pick&Place equipment using vacuum nozzles. It will not be damaged by the vacuum. Due to the low stress assembly the sensor does not show pressure hysteresis effects. Special care has to be taken to not touch the protective gel of the sensor during the assembly.

The MS5534A can be mounted with the cap down or the cap looking upwards. In both cases it is important to solder all contact pads. The Pins PEN and PV shall be left open or connected to Vdd.

DO NOT CONNECT TO GND !

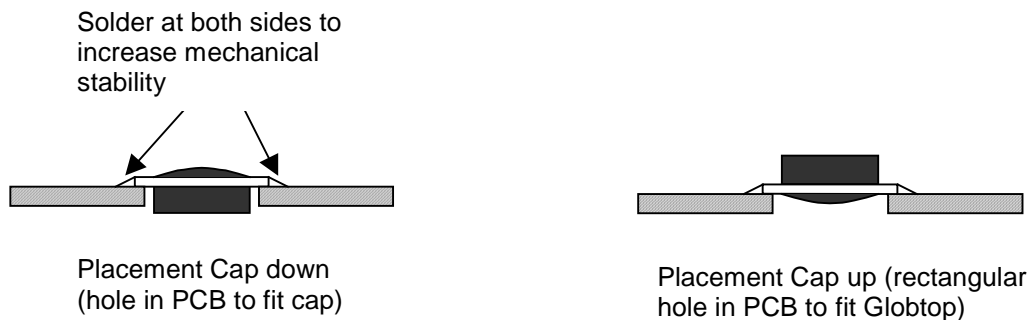

◆ Sealing with O-Ring

In products like outdoor watches the electronics must be protected against direct water or humidity. For those products the MS5534-AM provides the possibility to seal with an O-Ring. The protective cap of the MS5534-AM is made of special anticorrosive stainless steel with a polished surface. In addition to this the MS5534-AM is filled with silicone gel covering the sensor and the bonding wires. The O-Ring (or O-Rings) shall be placed at the outer diameter of the metal cap. This method avoids mechanical stress because the sensor can move in vertical direction.

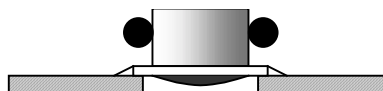

◆ Cleaning

The MS5534A has been manufactured under cleanroom conditions. Each device has been inspected for the homogeneity and the cleanliness of the silicone gel. It is therefore recommended to assemble the sensor under class 10'000 or better conditions. Should this not be possible, it is recommended to protect the sensor opening during assembly from entering particles and dust. To avoid cleaning of the PCB, solder paste of type "No-Clean" shall be used.

CLEANING MIGHT DAMAGE THE SENSOR.

◆ ESD Precautions

The electrical contacts except programming pads are protected against ESD according to 2KV HBM (human body model). The programming pads are more sensitive due to the nature of the OTP programming cells that store the calibration coefficients. The breakdown voltage of PEN and PV is 800V typical. It is therefore essential to ground machines and personal properly during assembly and handling of the device. The MS5534A is shipped in antistatic transport boxes. Any test adapters or production transport boxes used during the assembly of the sensor shall be of an equivalent antistatic material.

ORDERING INFORMATION

Product Code	Product	Package	Comments
MS5534AP	Barometer Module with plastic cap	SMD hybrid with solder paste, plastic protection cap	standard version
MS5534AM	Barometer Module with metal cap	SMD hybrid with solder paste, metal protection cap, silicon gel sensor protection	Recommended for outdoor products

FACTORY CONTACTS

Intersema Sensoric SA
Ch. Chapons-des-Prés 11
CH-2022 BEVAIX

SWITZERLAND

Tel. (032) 847 9550
Tel. Int. +41 32 847 9550
Telefax +41 32 847 9569
e-mail: sales@intersema.ch
<http://www.intersema.com>

LOCAL DISTRIBUTOR

Germany:

AMSYS GmbH
An der Fahrt 13
D-55124 Mainz
Tel. Int. +49 6131 46 98 75 55
Telefax +49 6131 46 98 75 66
<http://www.amsys.de>

USA:

Servoflo Cooperation
75 Allen Street
Lexington, MA 02421
Tel. Int. +1 781 862 9572
Telefax +1 781 862 9244
<http://www.servoflo.com>

NOTICE

Intersema reserves the right to make changes to the products contained in this data sheet in order to improve the design or performance and to supply the best possible products. Intersema assumes no responsibility for the use of any circuits shown in this data sheet, conveys no license under any patent or other rights unless otherwise specified in this data sheet, and makes no claim that the circuits are free from patent infringement. Applications for any devices shown in this data sheet are for illustration only and Intersema makes no claim or warranty that such applications will be suitable for the use specified without further testing or modification.