

PRODUCT DESCRIPTION

This low cost sub-miniature LED voltmeter module is ideally suited for high volume applications. It features an exceptionally large display in a miniature package and includes auto-zero and user-selectable decimal points. The use of low current display technology means this LED product can be considered for battery powered applications. The OEM 1B-LED is dimensionally compatible with its LCD counterpart, the OEM 1B. Connection to the module is via two rows of pins.

FEATURES

- 8mm (0.31") Digit Height
- 200mV d.c. Full Scale Reading
- 50mA (typ) @ +5V d.c. Power Supply
- Auto-zero and Auto-polarity
- User Selectable Decimal Points
- DIL Pin Connection
- Size compatible with OEM 1B (LCD module)

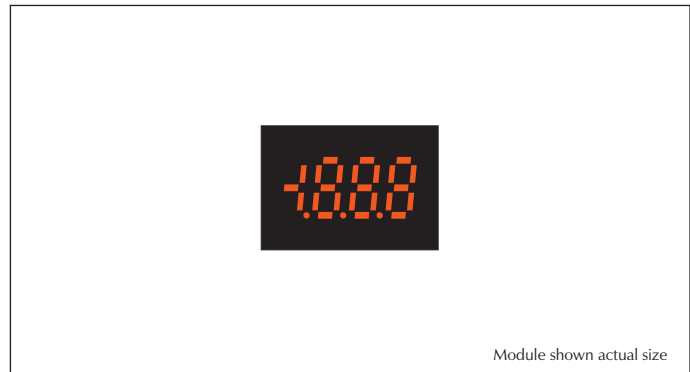

TYPICAL APPLICATIONS

- High Volume, Low Cost Systems
- Power Supply Monitoring
- Handheld Indication
- Panel-Mount Indication

ORDERING INFORMATION

Standard Meter

Stock Number
OEM1B - LED

ELECTRICAL SPECIFICATIONS

Specification	Min.	Typ.	Max.	Unit
Accuracy (overall error) *		0.05	0.1	% (± 1 count)
Linearity			± 1	count
Sample rate		2.5		samples/sec
Operating temperature range	0		50	$^{\circ}\text{C}$
Temperature stability		150		ppm/ $^{\circ}\text{C}$
Warm-up time		10		minutes
Supply voltage	4.75	5	5.25	V d.c.
Supply current **		50	100	mA
Input leakage current		1	10	pA

* To ensure maximum accuracy, re-calibrate periodically.

** Depends on reading and temperature.

Unless otherwise noted, specifications apply at $T_A = 25^{\circ}\text{C}$, $V_{\text{supply}} = 5\text{Vd.c.}$ ($f_{\text{clock}} = 40\text{kHz}$) and are tested with the module configured for floating input mode.

SAFETY

To comply with the Low Voltage Directive (LVD 93/68/EEC), input voltages to the module's pins must not exceed 60Vdc. The user must ensure that the incorporation of the panel meter into the user's equipment conforms to the relevant sections of BS EN 61010 (Safety Requirements for Electrical Equipment for Measuring, Control and Laboratory Use).

LASCAR ELECTRONICS LTD.
MODULE HOUSE
WHITEPARISH
WILTSHIRE SP5 2SJ
UK
TEL: +44 (1794) 884567
FAX: +44 (1794) 884616
E-mail: sales@lascar.co.uk

LASCAR ELECTRONICS INC.
3750 West 26th Street
Erie
PA 16506
USA
TEL: +1 (814) 835 0621
FAX: +1 (814) 838 8141
E-mail: us-sales@lascarelectronics.com

LASCAR ELECTRONICS (HK) LIMITED
FLAT C, 5/F., LUCKY FTY. BLDG.
63-65 HUNG TO ROAD
KWUN TONG KOWLOON
HONG KONG
TEL: +852 2797 3219
FAX: +852 2343 6187
E-mail: b4lascar@samsongroup.com.hk

DIMENSIONS

All dimensions in mm (inches)

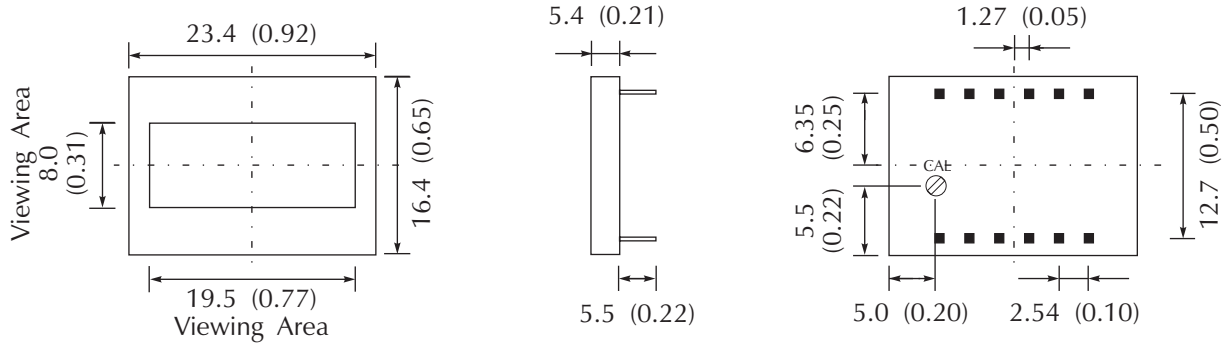

FUNCTIONAL BLOCK DIAGRAM

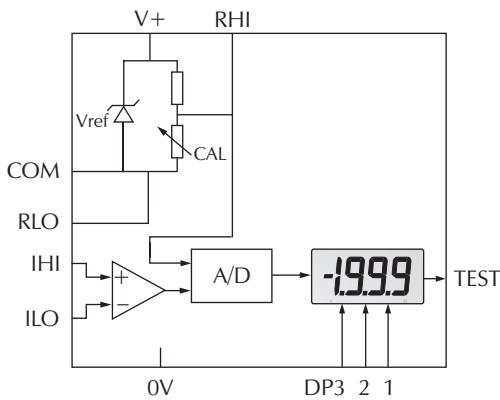

PIN CONFIGURATION (rear view)

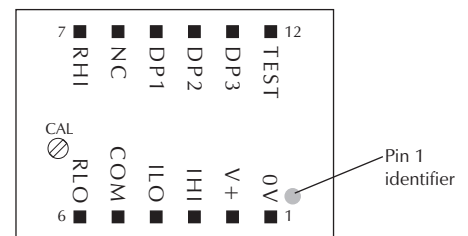

CIRCUIT DIAGRAM

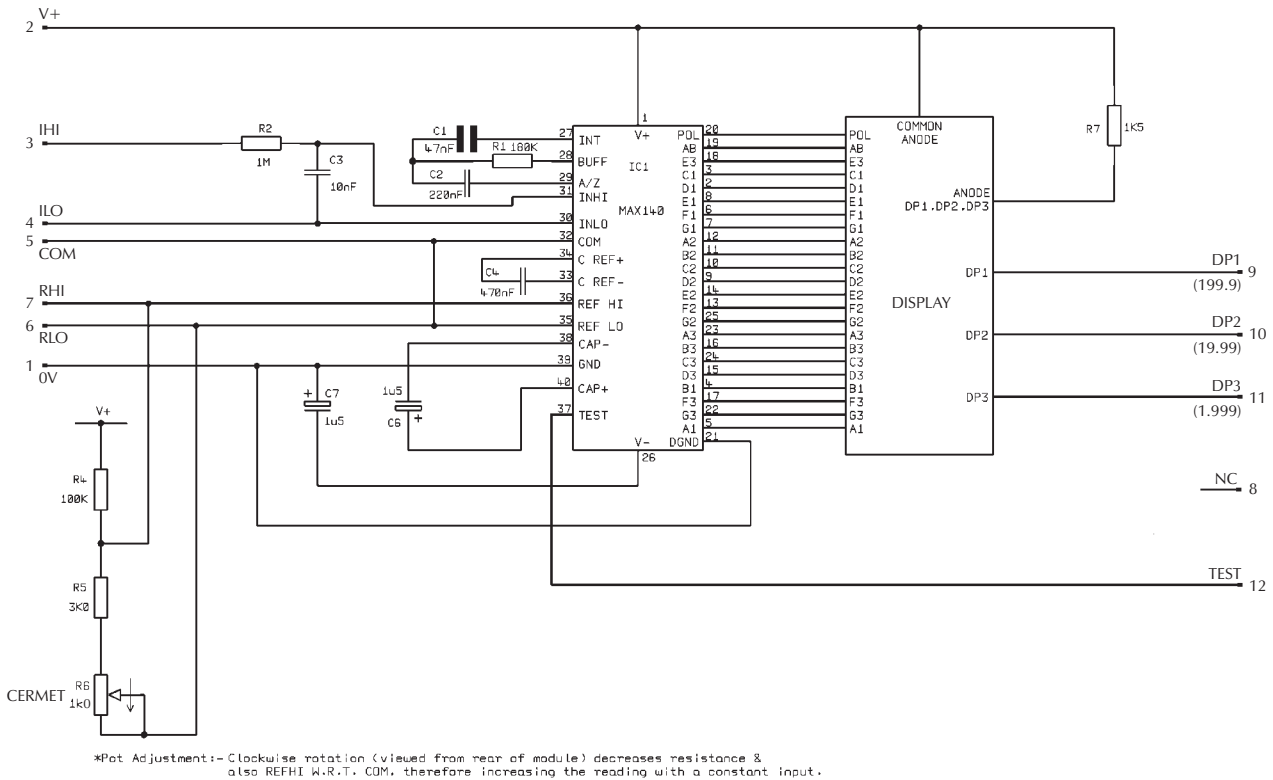

PIN FUNCTIONS

1. 0V Negative power supply to the meter.
2. V+ Positive power supply to the meter.
3. IHI Positive measuring input.
IHI must be no closer than 1.5V to either the positive or negative supply (see Note).
4. ILO Negative measuring input.
ILO must be no closer than 1.5V to the positive supply (see Note).
5. COM Ground for the analogue section of the A/D converter. It is actively held at 3.05V (nom.) below V+ and must not be allowed to sink excessive current (>100µA) by, for instance, connecting to a higher voltage.
6. RLO Negative input for the reference voltage.
7. RHI Positive input for the reference voltage.
8. NC Not connected.
9. DP1 Connect to 0V to display DP1 (199.9).
10. DP2 Connect to 0V to display DP2 (19.99).
11. DP3 Connect to 0V to display DP3 (1.999).
12. TEST Connect to V+ to display all segments, except the decimal points.

Note:

A negative supply is generated internally and mirrors the positive supply. For example: if V+ is +5V, then the internally generated V- is -5V. When measuring with the input referenced to the same supply rail as that of the panel meter, then the limitations on the input range are (V- + 1.5V) to (V+ - 1.5V).

EXTERNAL SCALING

Two external resistors Ra and Rb may be used to alter the full scale reading (FSR) of the meter - see table. The meter will have to be re-calibrated by adjusting the calibration potentiometer on the rear of the module.

	FSR	Ra	Rb
Voltage Vin	2V	910k	100k
	20V	1M	10k
	200V	1M	1k
	2000V*	1M	100R
Current Iin	200µA	0R	1k
	2mA	0R	100R
	20mA	0R	10R
	200mA	0R	1R

*Ensure that Ra is rated for high voltage use.

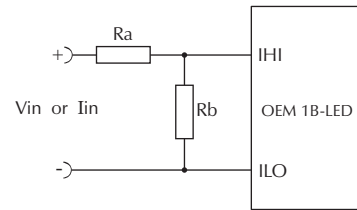

APPLICATIONS

Do not connect more than one meter to the same power supply if the meters cannot use the same signal ground. Taking any input beyond the power supply rails will damage the meter.

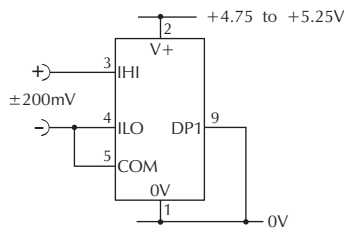

Measuring an input voltage referenced to a floating supply, i.e. the input voltage and the meter's power supply are isolated from each other. Circuit shows DP1 enabled.

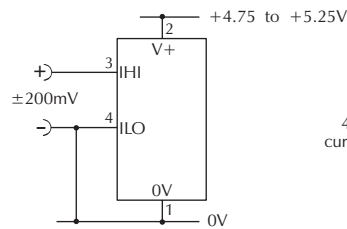

Measuring a single ended input voltage referenced to supply, i.e. the input voltage and the meter's power supply share the same 0V rail.

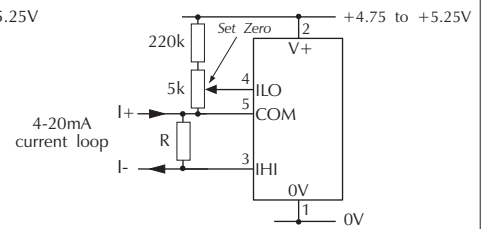

Measuring a 4-20mA loop current.

$$R = \frac{\text{Reading at 20mA}}{160}$$

The meter's power supply must be isolated from the 4-20mA current loop.

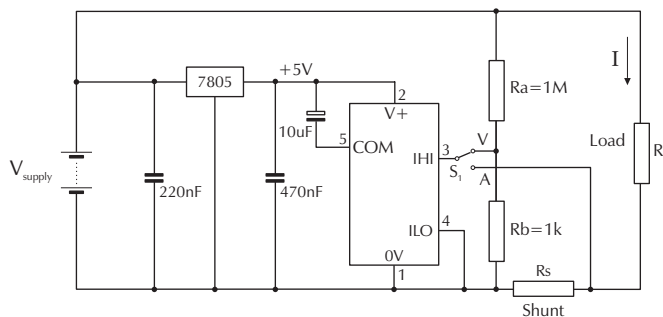

Measuring supply voltage and current to a load.

S₁ selects between voltage and current measurement.

$$R_s = \frac{200\text{mV}}{I_{\text{FSR}}} \quad (\text{e.g. } 0.1\Omega / 400\text{mW for 2A full scale})$$

Display DP1, DP2 or DP3, by connecting to 0V, as required.

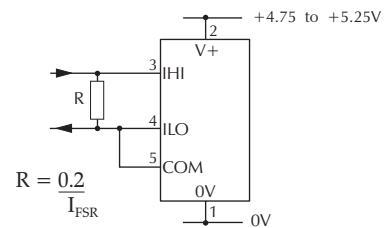

Measuring current.

The meter's supply is isolated from the current being measured.