



599 Menlo Drive, Suite 100  
Rocklin, California 95765, USA  
Office: (916) 624-8333  
Fax: (916) 624-8003

General: info@parallax.com  
Technical: support@parallax.com  
Web Site: www.parallax.com  
Educational: www.stampsinclass.com

---

## Parallax Serial LCD

2 rows x 16 characters Non-backlit (#27976)

2 rows x 16 characters Backlit (#27977)

4 rows x 20 characters Backlit (#27979)

### Introduction

The Parallax Serial LCDs are very functional, low-cost LCDs that can be easily controlled by a BASIC Stamp<sup>®</sup> microcontroller. The LCD displays are either two rows by 16 characters or four rows by 16 characters, and provide basic text wrapping so that your text looks right on the display. In addition, the Serial LCDs also provide you with full control over all of their advanced LCD features, allowing you to move the cursor anywhere on the display with a single instruction and turn the display on and off in any configuration. They support the same visible characters as the BASIC Stamp Editor's Debug Terminal (ASCII Dec 32-127). In addition, you may define up to eight of your own custom characters to display anywhere on the LCD.

What can you do with a Parallax Serial LCD? While there are many possibilities, here's a small list of ideas that can be realized with a Serial LCD and the Parallax BASIC Stamp:

- A professional-looking text user interface on any microcontroller application
- Easy-to-implement serial debugging without a PC
- Real-time sensor data output on autonomous robotics applications (BOE-Bot, Scribbler, Toddler, SumoBot)

### Packing List

Verify that your Serial LCD is complete in accordance with the list below:

- Parallax Serial LCD module
- Documentation

Demonstration BASIC Stamp software files may be downloaded from

[http://www.parallax.com/detail.asp?product\\_id=27976](http://www.parallax.com/detail.asp?product_id=27976)

[http://www.parallax.com/detail.asp?product\\_id=27977](http://www.parallax.com/detail.asp?product_id=27977)

[http://www.parallax.com/detail.asp?product\\_id=27979](http://www.parallax.com/detail.asp?product_id=27979)

## Features

- Displays ASCII character set directly to the display
- Wraps to the next line automatically for easy display of text strings
- Works at 2400, 9600, and 19,200 baud
- Moves the cursor anywhere on the display with a single command
- Clears the whole display with a single command
- Allows you to define up to eight custom characters

## Connections

Connecting the Serial LCD to the BASIC Stamp is a straightforward operation, requiring just three IO pins. See Figure 1a and 1b for electrical connection details. See Figures 2 and 3 for size and mechanical mounting details.

**Figure 1a. Serial LCD Connections for Rev D and earlier displays**

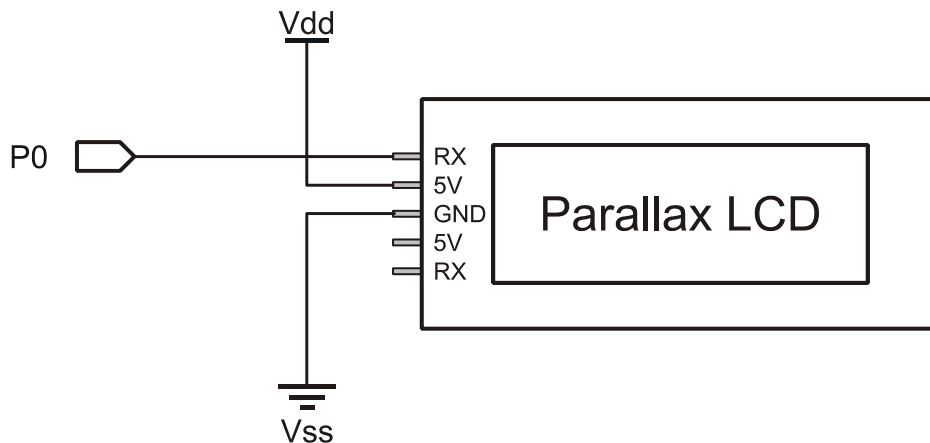

**Figure 1b. Serial LCD Connections for Rev E and later displays**

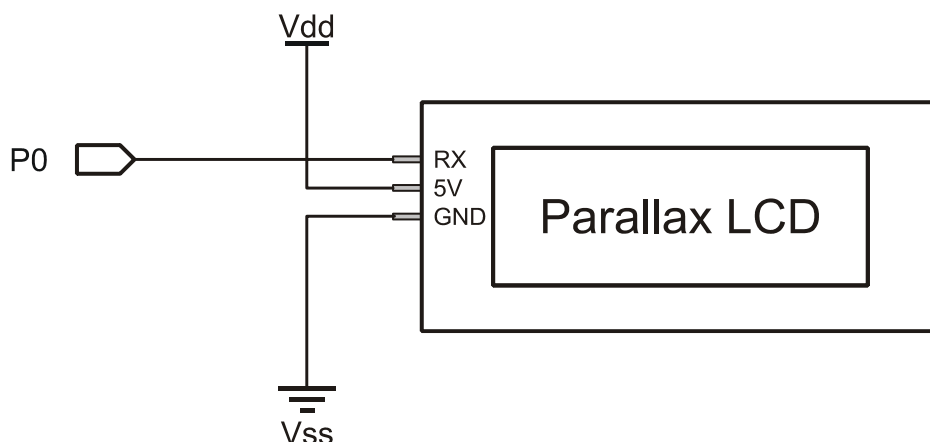

The table below lists the voltage and current requirements of the Serial LCD, with the backlight turned on and off. Since the current draw in either case exceeds the capabilities of all of the BASIC Stamp modules, you should power the Serial LCD from an external 5 V power supply. Make sure the power supply has an adequate current rating to power the Serial LCD and the BASIC Stamp.

Serial LCD State	Voltage	Current
All Models Backlight off	5 VDC	20 mA
27977/27979 Backlight on	5 VDC	80 mA

**Figure 2. Size and Mounting Specifications for Models 27976, 27977**

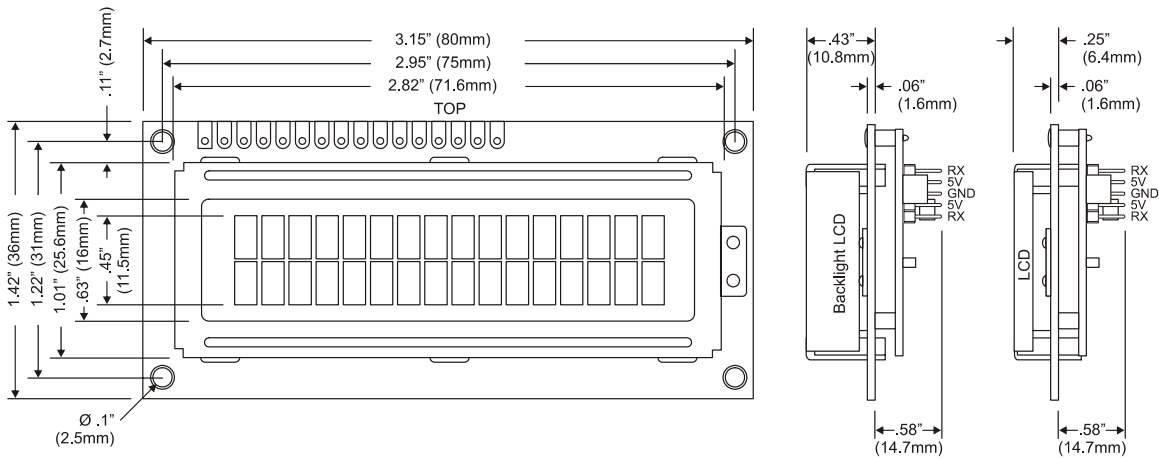

**Figure 3. Size and Mounting Specifications for Model 27979**

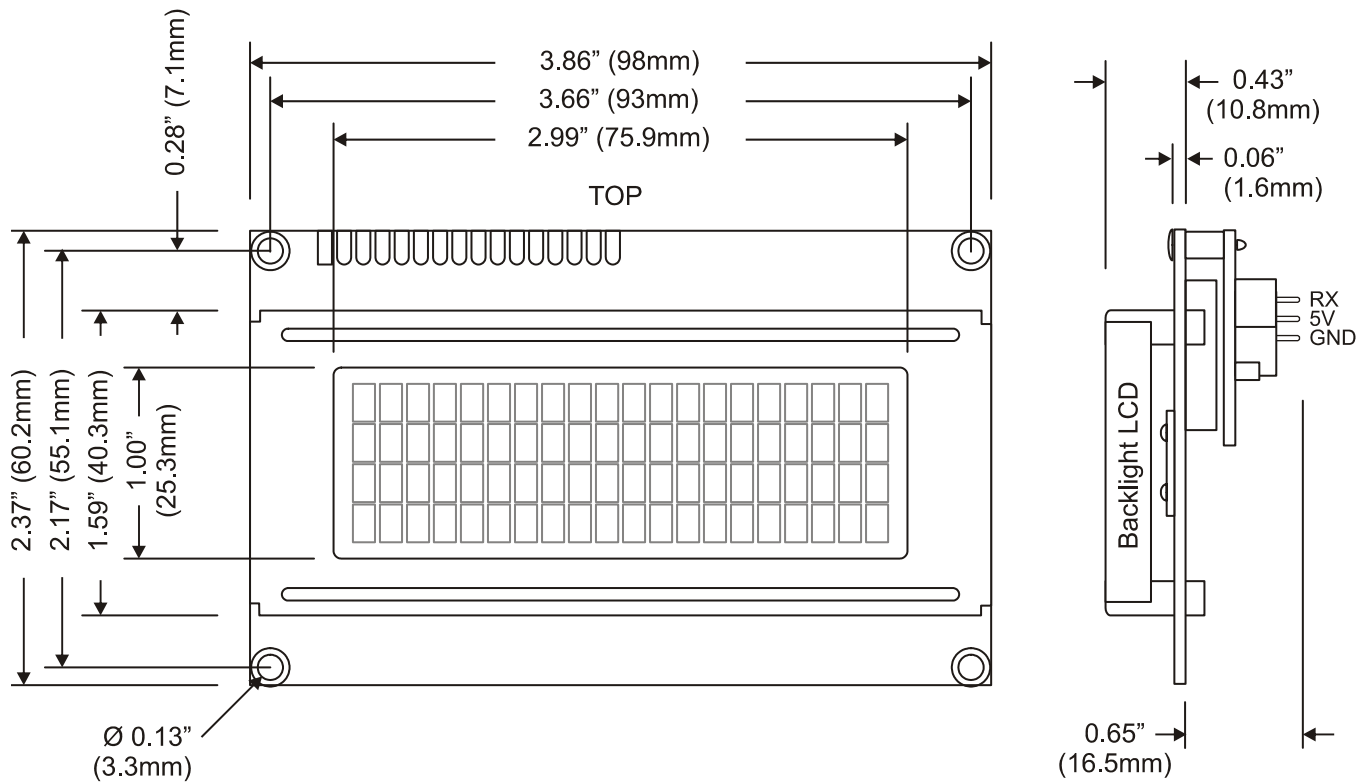

## Technical Notes

LCD display type: STN, YG, positive, transfective  
Viewing direction: 6H  
Backlight: YG LED  
Operating temperature: -4°F~158°F (-20°C~70°C)  
Storage temperature: -22°F~176°F (-30°C~80°C)  
Dimension tolerance: ±.02" (.5mm)

## Baud Rate Setup

After connecting the Serial LCD, you will need to select the baud rate at which you are going to send it data. You have three choices: 2400, 9600, and 19,200 baud. To set the baud rate, move the dip switches on the back of the LCD into the correct positions according to the table next to the switches, which is also repeated below:

MODE	SW1	SW2
Test	OFF	OFF
2,400	ON	OFF
9,600	OFF	ON
19.200	ON	ON

As you can see from the table, there is also a fourth choice called Test. Now that you've connected the power, use this Test mode to confirm that the power and ground to the LCD are hooked up correctly before you send it any data. Move the dip switches to the Test setting and turn on the power. The LCD display should turn on with the backlight on (models 27977, 27979) and display the following text:

Parallax, Inc.  
www.parallax.com

If you don't see the text at first, try adjusting the LCD contrast by turning the pot labeled "Increase Contrast" with a screwdriver. Turn it in the direction of the arrow to make the characters show up more clearly. If you still don't see the characters, go back and check your electrical connections and try again. Once you've successfully completed test mode, move the dip switches to the correct positions to select the baud rate you want to use for your application.

## Displaying Text

Now that the LCD is set up, it's time to start sending text to the display. To display a character of text on the Serial LCD, simply send the ASCII code of that character to the Serial LCD over the serial port at the correct baud rate.

When a character is received, the Serial LCD displays that character at the current cursor position and then moves the cursor one position to the right. When you first turn on the LCD, the cursor is in the leftmost position on the top line, as you might expect. The short bar on the bottom of the character shows where the cursor is positioned currently.

Once you've sent a full line characters to the LCD, you will notice that the cursor automatically wraps around to the leftmost position of the second line, just like the text in a book. The text will wrap like this

at the end of every line, with the end of the bottom line wrapping back around to the top line of the LCD. The text will never “run off” the display; you’ll always see all of the characters you send.

Try the following code on your BASIC Stamp 2 to send a text string to the LCD display. First, set the baud rate on your Serial LCD to 19,200. Then, load the code below into your BASIC Stamp 2 and run it. You will see the text string show up and wrap to the second line of the display.

In all of your Serial LCD code, you should pause for 100 ms at start-up to give time for the Serial LCD to initialize. You should also set the serial port pin on the BASIC Stamp to HIGH before the 100 ms start-up delay, as this is the normal state of a serial port when it isn’t sending any data.

```
' {$STAMP BS2}

TxPin          CON      0
Baud19200      CON      32

HIGH TxPin          ' Set pin high to be a serial port
PAUSE 100          ' Pause for Serial LCD to initialize

SEROUT TxPin, Baud19200, ["Hello, this text will wrap."]
```

## Moving the Cursor

When you send a character to the Serial LCD, it always displays at the current cursor position. There are a few different ways to move the cursor on the Serial LCD display. After each character you send, the cursor automatically moves over one position. Along with this, there is a standard set of cursor move commands including Backspace, Carriage Return, and Line Feed.

The Backspace/Left command (Dec 8) moves the cursor one place to the left and the Right command (Dec 9) moves the cursor one place to the right. These can be useful for moving the cursor around to overwrite existing text. These commands wrap to the next line of the display, if necessary. The Line Feed command (Dec 10) moves the cursor to the next line of the display without changing the horizontal position of the cursor. The Carriage Return command (Dec 13) also moves the cursor to the next line, but it moves the cursor to the leftmost position on that line as well. The Form Feed command (Dec 12) clears the entire display and moves the cursor to the leftmost position on line 0, just like when you first turn on the display. You will need to pause for 5mS in your code after sending the Form Feed command, to give the Serial LCD time to clear the display. Except for Form Feed, none of these move commands affects the characters on the display.

There are also direct move commands that you can use to move the cursor to any position on the display with a single command. The commands in the range Dec 128 to 143 and Dec 148 to 163 move the cursor to the 16 different positions on each of the two lines of the model 27976 and 27977 LCDs. The commands in the range Dec 128 to 207 move the cursor to the 20 different positions on each of the four lines of the model 27979 LCD.

## Controlling the Display

You also have control over the various display modes of the Serial LCD. The display-off command (Dec 21) turns off the display so that all of the characters disappear. The characters aren’t erased from the display, though, and you can even keep writing new characters to the display when it is turned off. A

trick to make a lot of text show up all at once, even at a slow baud rate, is to turn off the display and then send all of your text. Then, when you turn the display on again, all of the text appears instantly.

The display-on commands (Dec 22 to 25) turn the display back on and also control whether you want to display the cursor and/or make the cursor character blink. The cursor is the short bar that shows up below the character at the current cursor position. The blink option makes that character blink on and off repeatedly. You can turn the cursor and blink options on or off, in any combination, as listed in the command set table. You can change the cursor and blink mode even if the display is already on; you don't need to turn it off and then back on again.

With models 27977 and 27979, you can also control the backlight of the display. The backlight lights up the display so that it is easier to see in the dark. There are commands to turn the backlight on (Dec 17) and off (Dec 18).

## Custom Characters

The Serial LCD has the capability to store up to eight user-defined custom characters. The custom characters are stored in RAM and so they need to be redefined if you turn off the power. You can display the custom characters by sending the commands Dec 0 to 7, as shown in the command set table. The custom character will display at the current cursor position.

The custom characters are five pixels wide by eight pixels high. Each of the characters is stored as a series of eight data bytes where the low five bits of each byte represent a row of pixels in the character. The high three bits of each byte are ignored. A bit value of one turns that pixel on (i.e. makes it black). The bottom row of pixels is often left blank (all zeros) to make it easier to see the cursor.

To define a custom character, you will send a total of 9 bytes to the Serial LCD. The first byte needs to be a valid define-custom-character command (Dec 248 to 255) and must be followed by eight data bytes that define the pixels of the character. The Serial LCD will always use the next eight bytes it receives to set the pixels of the character. The data bytes define the character starting at the topmost row of pixels, as shown in the example code.

Define a custom character using the code example below. First, set the baud rate on your Serial LCD to 19,200. Then, load the code below into your BASIC Stamp 2 and run it. You will see a diamond character appear on the screen.

```
' {$STAMP BS2}

TxPin          CON      0
Baud19200      CON      32

HIGH TxPin          ' Set pin high to be a serial port
PAUSE 100           ' Pause for Serial LCD to initialize

SEROUT TxPin, Baud19200, [250] ' Define custom character 2
                          ' Now send the eight data bytes
SEROUT TxPin, Baud19200, [0]  ' 0 = %00000
SEROUT TxPin, Baud19200, [4]  ' 4 = %00100      *
SEROUT TxPin, Baud19200, [14] ' 14 = %01110     * * *
SEROUT TxPin, Baud19200, [31] ' 31 = %11111     * * * * *
SEROUT TxPin, Baud19200, [14] ' 14 = %01110     * * *
SEROUT TxPin, Baud19200, [4]  ' 4 = %00100      *
SEROUT TxPin, Baud19200, [0]  ' 0 = %00000
SEROUT TxPin, Baud19200, [0]  ' 0 = %00000
SEROUT TxPin, Baud19200, [2]  ' Display the new custom character 2
```

## Command Set

The tables below list all of the valid Serial LCD commands. Commands marked as N/A are invalid and are ignored. The lines of the LCD display are numbered starting from 0, with line 0 being the top line. The character positions on each line are numbered starting from 0, with position 0 being the leftmost position on the line.

Dec	Hex	Action
0	00	Display custom character 0
1	01	Display custom character 1
2	02	Display custom character 2
3	03	Display custom character 3
4	04	Display custom character 4
5	05	Display custom character 5
6	06	Display custom character 6
7	07	Display custom character 7
8	08	Backspace / Left - The cursor is moved one position to the left. The command doesn't erase the character.
9	09	Right - The cursor is moved one position to the right. The command doesn't erase the character.
10	0A	Line Feed - The cursor is moved down one line. For the two line LCD model, if on line 0 it goes to line 1. If on line 1, it wraps around to line 0. The horizontal position remains the same.
11	0B	N/A
12	0C	Form Feed - The cursor is moved to position 0 on line 0 and the entire display is cleared. Users must pause 5mS after this command.
13	0D	Carriage Return - For the two line LCD model, if on line 0 the cursor is moved to position 0 on line 1. If on line 1, it wraps around to position 0 on line 0.
14 - 16	0E - 10	N/A
17	11	Turn backlight on (only on models 27977, 27979)
18	12	Turn backlight off (Default)
19 - 20	13 - 14	N/A
21	15	Turn the display off
22	16	Turn the display on, with cursor off and no blink
23	17	Turn the display on, with cursor off and character blink
24	18	Turn the display on, with cursor on and no blink (Default)
25	19	Turn the display on, with cursor on and character blink
26 - 31	1A - 1F	N/A
32 - 127	20 - 7F	Display ASCII characters. See the ASCII character set table.
128	80	Move cursor to line 0, position 0
129	81	Move cursor to line 0, position 1
130	82	Move cursor to line 0, position 2
131	83	Move cursor to line 0, position 3
132	84	Move cursor to line 0, position 4
133	85	Move cursor to line 0, position 5
134	86	Move cursor to line 0, position 6

Dec	Hex	Action
135	87	Move cursor to line 0, position 7
136	88	Move cursor to line 0, position 8
137	89	Move cursor to line 0, position 9
138	8A	Move cursor to line 0, position 10
139	8B	Move cursor to line 0, position 11
140	8C	Move cursor to line 0, position 12
141	8D	Move cursor to line 0, position 13
142	8E	Move cursor to line 0, position 14
143	8F	Move cursor to line 0, position 15
144	90	Move cursor to line 0, position 16 (only on model 27979)
145	91	Move cursor to line 0, position 17 (only on model 27979)
146	92	Move cursor to line 0, position 18 (only on model 27979)
147	93	Move cursor to line 0, position 19 (only on model 27979)
148	94	Move cursor to line 1, position 0
149	95	Move cursor to line 1, position 1
150	96	Move cursor to line 1, position 2
151	97	Move cursor to line 1, position 3
152	98	Move cursor to line 1, position 4
153	99	Move cursor to line 1, position 5
154	9A	Move cursor to line 1, position 6
155	9B	Move cursor to line 1, position 7
156	9C	Move cursor to line 1, position 8
157	9D	Move cursor to line 1, position 9
158	9E	Move cursor to line 1, position 10
159	9F	Move cursor to line 1, position 11
160	A0	Move cursor to line 1, position 12
161	A1	Move cursor to line 1, position 13
162	A2	Move cursor to line 1, position 14
163	A3	Move cursor to line 1, position 15
164	A4	Move cursor to line 1, position 16 (only on model 27979)
165	A5	Move cursor to line 1, position 17 (only on model 27979)
166	A6	Move cursor to line 1, position 18 (only on model 27979)
167	A7	Move cursor to line 1, position 19 (only on model 27979)
168	A8	Move cursor to line 2, position 0 (only on model 27979)
169	A9	Move cursor to line 2, position 1 (only on model 27979)
170	AA	Move cursor to line 2, position 2 (only on model 27979)
171	AB	Move cursor to line 2, position 3 (only on model 27979)
172	AC	Move cursor to line 2, position 4 (only on model 27979)
173	AD	Move cursor to line 2, position 5 (only on model 27979)
174	AE	Move cursor to line 2, position 6 (only on model 27979)
175	AF	Move cursor to line 2, position 7 (only on model 27979)
176	B0	Move cursor to line 2, position 8 (only on model 27979)
177	B1	Move cursor to line 2, position 9 (only on model 27979)
178	B2	Move cursor to line 2, position 10 (only on model 27979)
179	B3	Move cursor to line 2, position 11 (only on model 27979)
180	B4	Move cursor to line 2, position 12 (only on model 27979)



Dec	Hex	Action
181	B5	Move cursor to line 2, position 13 (only on model 27979)
182	B6	Move cursor to line 2, position 14 (only on model 27979)
183	B7	Move cursor to line 2, position 15 (only on model 27979)
184	B8	Move cursor to line 2, position 16 (only on model 27979)
185	B9	Move cursor to line 2, position 17 (only on model 27979)
186	BA	Move cursor to line 2, position 18 (only on model 27979)
187	BB	Move cursor to line 2, position 19 (only on model 27979)
188	BC	Move cursor to line 3, position 0 (only on model 27979)
189	BD	Move cursor to line 3, position 1 (only on model 27979)
190	BE	Move cursor to line 3, position 2 (only on model 27979)
191	BF	Move cursor to line 3, position 3 (only on model 27979)
192	C0	Move cursor to line 3, position 4 (only on model 27979)
193	C1	Move cursor to line 3, position 5 (only on model 27979)
194	C2	Move cursor to line 3, position 6 (only on model 27979)
195	C3	Move cursor to line 3, position 7 (only on model 27979)
196	C4	Move cursor to line 3, position 8 (only on model 27979)
197	C5	Move cursor to line 3, position 9 (only on model 27979)
198	C6	Move cursor to line 3, position 10 (only on model 27979)
199	C7	Move cursor to line 3, position 11 (only on model 27979)
200	C8	Move cursor to line 3, position 12 (only on model 27979)
201	C9	Move cursor to line 3, position 13 (only on model 27979)
202	CA	Move cursor to line 3, position 14 (only on model 27979)
203	CB	Move cursor to line 3, position 15 (only on model 27979)
204	CC	Move cursor to line 3, position 16 (only on model 27979)
205	CD	Move cursor to line 3, position 17 (only on model 27979)
206	CE	Move cursor to line 3, position 18 (only on model 27979)
207	CF	Move cursor to line 3, position 19 (only on model 27979)
208 - 247	D0 – F7	N/A
248	F8	Define custom character 0. This command must be followed by eight data bytes.
249	F9	Define custom character 1. This command must be followed by eight data bytes.
250	FA	Define custom character 2. This command must be followed by eight data bytes.
251	FB	Define custom character 3. This command must be followed by eight data bytes.
252	FC	Define custom character 4. This command must be followed by eight data bytes.
253	FD	Define custom character 5. This command must be followed by eight data bytes.
254	FE	Define custom character 6. This command must be followed by eight data bytes.
255	FF	Define custom character 7. This command must be followed by eight data bytes.

## ASCII Character Set

The table below shows all of all the ASCII characters as they are displayed on the Serial LCD. All of the ASCII characters (Dec 32 to 127) are standard ASCII characters, except for the '\ ' back-slash (Dec 92) and '~' tilde (Dec 126) characters. For your convenience, the Serial LCD comes pre-programmed with these characters in the first two custom characters. So, to display a back-slash, use command Dec 0 and to display a tilde, use command Dec 1. Of course, you can always overwrite these characters with your own custom characters.

Lower 4 Bits \ Upper 4 Bits	0000	0001	0010	0011	0100	0101	0110	0111
xxxx0000	CG RAM (1)			0	@	P	`	P
xxxx0001	(2)		!	1	A	Q	a	q
xxxx0010	(3)		"	2	B	R	b	r
xxxx0011	(4)		#	3	C	S	c	s
xxxx0100	(5)		\$	4	D	T	d	t
xxxx0101	(6)		%	5	E	U	e	u
xxxx0110	(7)		&	6	F	V	f	v
xxxx0111	(8)		'	7	G	W	g	w
xxxx1000	(1)		(	8	H	X	h	x
xxxx1001	(2)		)	9	I	Y	i	y
xxxx1010	(3)		*	:	J	Z	j	z
xxxx1011	(4)		+	;	K	[	k	{
xxxx1100	(5)		,	<	L	¥	l	l
xxxx1101	(6)		-	=	M	]	m	}
xxxx1110	(7)		.	>	N	^	n	+
xxxx1111	(8)		/	?	O	_	o	€